

# Zebra

## Two-Stage Rotary Vane Vacuum Pumps RH 0030–0090 B

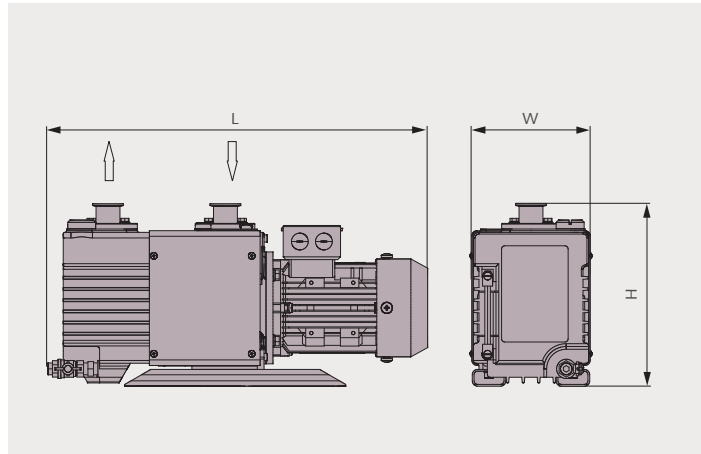

Zebra RH 0030–0090 B



Pumping speed Air at 20 °C. Tolerance: ± 10% — 50 Hz - - - - 60 Hz

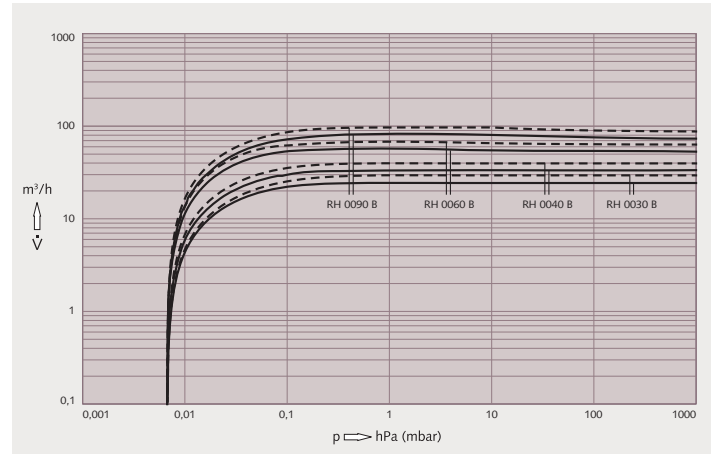

Technical data			RH 0030 B	RH 0040 B	RH 0060 B	RH 0090 B
Pumping speed	50 Hz / 60 Hz	m³/h	24 / 29	33 / 39	55 / 65	80 / 95
Pumping speed	50 Hz / 60 Hz	l/min	400 / 483	550 / 650	917 / 1083	1333 / 1583
Ultimate partial pressure	Gas-ballast valve closed	hPa (mbar)	$6.7 \cdot 10^{-4}$	$6.7 \cdot 10^{-4}$	$6.7 \cdot 10^{-4}$	$6.7 \cdot 10^{-4}$
Ultimate total pressure	Gas-ballast valve closed	hPa (mbar)	$6.7 \cdot 10^{-3}$	$6.7 \cdot 10^{-3}$	$6.7 \cdot 10^{-3}$	$6.7 \cdot 10^{-3}$
Ultimate total pressure	Gas-ballast valve open	hPa (mbar)	$2 \cdot 10^{-2}$	$2 \cdot 10^{-2}$	$2 \cdot 10^{-2}$	$2 \cdot 10^{-2}$
Max. continuous inlet pressure		hPa (mbar)	65	65	65	10
Max. back pressure (gauge)		hPa (mbar)	300	300	300	300
Water vapour capacity	Gas-ballast valve open	g/h	190 / 250	270 / 410	430 / 1100	480 / 600

Motor data three-phase version						
Nominal motor rating		kW	1.5	1.5	2.2	3.7
Energy efficiency class			IE3	IE3	IE3	IE3
Operating voltage	50 Hz 60 Hz	V	200–240 / 380–415 200–240 / 380–460	200–240 / 380–415 200–240 / 380–460	200–240 / 380–415 200–240 / 380–460	200–240 / 380–415 200–240 / 380–460

Physical data						
Ambient temperature		°C	4–40	4–40	4–40	4–40
Oil			VMA 055	VMA 055	VMA 055	VMA 055
Oil capacity		l	2.5	2.5	4	4
Noise level (ISO 2151)	50 Hz / 60 Hz	dB(A)	< 57 / < 61	< 60 / < 64	< 60 / < 64	< 60 / < 66
Weight approx.		kg	58	60	90	113
Dimensions (L x W x H)		mm	671 x 214 x 326	691 x 214 x 326	772 x 264 x 373	831 x 264 x 373
Gas inlet / outlet			ISO-KF 40 / ISO-KF 40	ISO-KF 40 / ISO-KF 40	ISO-KF 40 / ISO-KF 40	ISO-K 63 / ISO-KF 40

Applicable standards						
Marking			cTUVus	cTUVus	cTUVus	cTUVus

www.buschvacuum.com

Argentina Australia বাংলাদেশ België Brasil Canada Česko Chile 中国 Colombia Danmark Deutschland España France भारत गणराज्य Ireland ישראל Italia 日本 대한민국 Magyarország Malaysia México Nederland New Zealand Norge Österreich Perú Polska Portugal România Россия Schweiz Singapore South Africa Suomi Sverige 台湾 ประเทศไทย Türkiye الإمارات العربية المتحدة United Kingdom USA

Technical data is subject to change. Created in Germany. MG PL ZEBRARH003000908 Len 09/2017 7Aa

# Zebra

## Two-Stage Rotary Vane Vacuum Pumps RH 0030–0090 B



Article Numbers, Genuine Accessories and Spare Parts	RH 0030 B	RH 0040 B	RH 0060 B	RH 0090 B
<b>With three-phase motor</b>				
200-240 / 380-460, 50/60 Hz	1141168799	1141168800	1141168801	1141168802
<b>Inlet accessories<sup>1</sup></b>				
Inlet filter FIL 0080	0530566434			-
Spare polyester filter element for FIL 0080	0532121862			-
Special purpose filter element for FIL 0080	on request			-
Inlet filter FIL 0350	-			0530168812
Spare polyester filter element for FIL 0350	-			0532121864
Special purpose filter element for FIL 0350	-			on request
<b>Outlet accessories<sup>2</sup></b>				
Oil mist separator OMS 0040	0960168806		-	
Spare filter element for OMS 0040	0532169044		-	
Oil mist separator OMS 0090	-		0960168807	
Spare filter element for OMS 0090	-		0532169045	
Oil return line	0946168809			
<b>Other accessories</b>				
Gas-ballast valve	0916168803			
<b>Oil</b>				
VMA 055, 1L	0831169415			
VMA 055, 5L	0831169416			
<b>Maintenance kits</b>				
Minor maintenance kit	0992168950	0992168952	0992168954	0992168956
Major maintenance kit	0993168951	0993168953	0993168955	0993168957

<sup>1</sup> All filters include housing, polyester filter element and mounting hardware  
<sup>2</sup> All oil mist separators include housing, filter element and mounting hardware