

# Instruction Manual

## Zebra

Two-Stage Rotary Vane Vacuum Pumps  
RH 0030 B, RH 0040 B, RH 0060 B, RH 0090 B



CE

Busch Produktions GmbH  
Schauinslandstraße 1, 79689 Maulburg  
Germany

# Table of Contents

<b>1 Safety</b> .....	<b>3</b>
<b>2 Product Description</b> .....	<b>4</b>
2.1 Operating Principle.....	4
2.2 Application .....	5
2.3 Optional Accessories.....	5
2.3.1 Gas Ballast Valve.....	5
2.3.2 Inlet Filter .....	5
2.3.3 Oil Mist Separator.....	5
<b>3 Transport</b> .....	<b>6</b>
<b>4 Storage</b> .....	<b>6</b>
<b>5 Installation</b> .....	<b>7</b>
5.1 Installation Conditions .....	7
5.2 Connecting Lines / Pipes .....	7
5.2.1 Suction Connection.....	8
5.2.2 Discharge Connection.....	8
5.2.3 Oil Mist Separator (Optional).....	9
5.3 Filling Oil.....	10
5.4 Electrical Connection .....	10
5.4.1 Wiring Diagram Three-Phase Motor .....	11
<b>6 Commissioning</b> .....	<b>11</b>
6.1 Continuous Operation .....	12
6.2 Conveying Condensable Vapours .....	12
<b>7 Maintenance</b> .....	<b>12</b>
7.1 Maintenance Schedule.....	13
7.2 Oil Change Recommendations .....	13
7.3 Oil Change.....	14
7.4 Coupling Maintenance .....	15
<b>8 Overhaul</b> .....	<b>16</b>
<b>9 Decommissioning</b> .....	<b>16</b>
9.1 Dismantling and Disposal.....	16
<b>10 Spare Parts</b> .....	<b>17</b>
<b>11 Accessories</b> .....	<b>17</b>
<b>12 Troubleshooting</b> .....	<b>18</b>
<b>13 Technical Data</b> .....	<b>20</b>
<b>14 Oil</b> .....	<b>20</b>
<b>15 EU Declaration of Conformity</b> .....	<b>21</b>

# 1 Safety

Prior to handling the machine this instruction manual should be read and understood. If anything needs to be clarified please contact your Busch representative.

Read carefully before use and keep for future reference.

This instruction manual remains valid as long as the customer does not change anything on the product.

The machine is intended for industrial use. It must be handled only by technically trained personnel.

The machine has been designed and manufactured according to state-of-the-art methods. Nevertheless, residual risks may remain. This instruction manual highlights potential hazards where appropriate. Safety notes and warning messages are tagged with one of the keywords DANGER, WARNING, CAUTION, NOTICE and NOTE as follows:

## **DANGER**

... indicates an imminent dangerous situation that will result in death or serious injuries if not prevented.

## **WARNING**

... indicates a potentially dangerous situation that could result in death or serious injuries.

## **CAUTION**

... indicates a potentially dangerous situation that could result in minor injuries.

## **NOTICE**

... indicates a potentially dangerous situation that could result in damage to property.

## **NOTE**

... indicates helpful tips and recommendations, as well as information for efficient and trouble-free operation.

## 2 Product Description

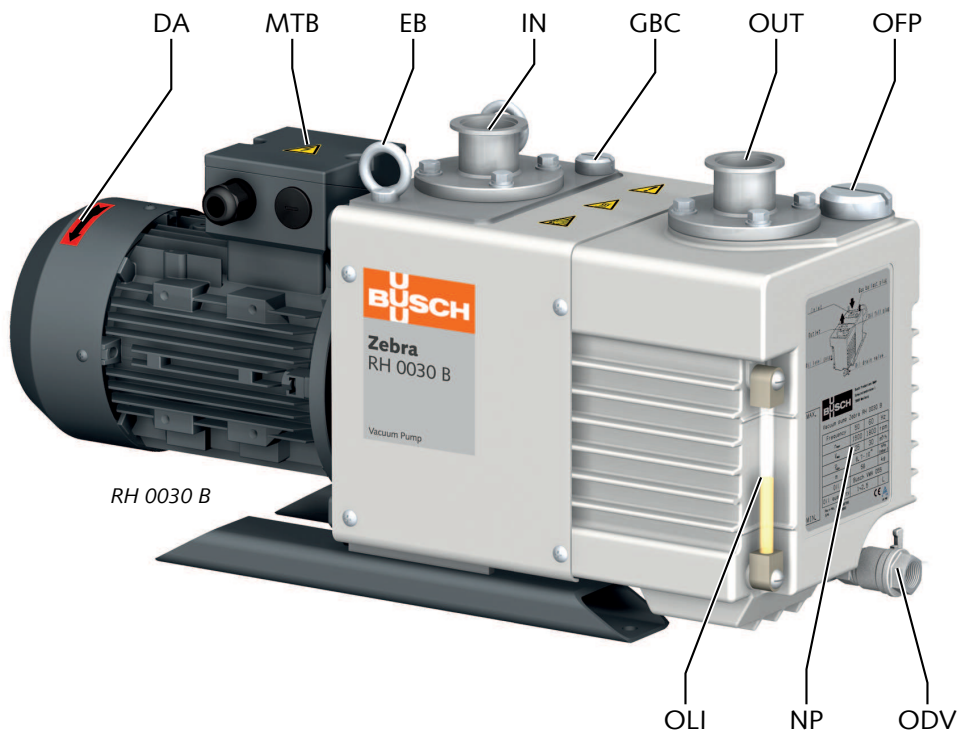

DA	Directional arrow	EB	Eye bolt
GBC	Gas ballast connection	IN	Suction connection
MTB	Motor terminal box	NP	Nameplate
ODV	Oil drain valve	OFF	Oil fill plug
OLI	Oil level indicator	OUT	Discharge connection

### NOTE

#### Technical term.

In this instruction manual, we consider that the term 'machine' refers to the 'vacuum pump'.

### 2.1 Operating Principle

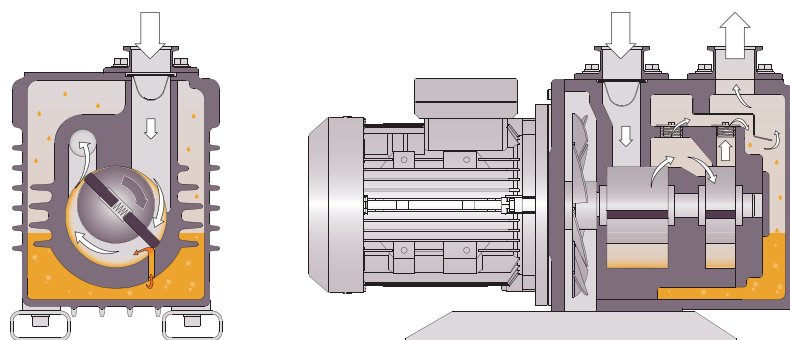

The machine works on the two-stage rotary vane principle.

The oil seals the gaps, lubricates the vanes and takes away compression heat.

## 2.2 Application

The machine is intended for the suction of air and other dry, non-aggressive, non-toxic and non-explosive gases.

Conveying of other media leads to an increased thermal and/or mechanical load on the machine and is permissible only after a consultation with Busch.

The machine is intended for the placement in a non-potentially explosive environment.

The machine is capable of maintaining ultimate pressure.

The machine is suitable for continuous operation under certain conditions, see Continuous Operation [▶ 12].

Permitted environmental conditions see Technical Data [▶ 20].

### NOTICE

Chemical compatibility of the process gases with the machine component materials.

**Risk of corrosion inside the compression chamber which can reduce performance and its lifetime!**

- Check if the process gases are compatible with those following materials:
  - Cast iron
  - Steel
  - Aluminium
  - Fluoroelastomer (FKM/FPM)
- In doubt, please contact your Busch representative.

## 2.3 Optional Accessories

### 2.3.1 Gas Ballast Valve

It mixes the process gas with a limited quantity of ambient air to counteract the condensation of vapour inside the machine.

### 2.3.2 Inlet Filter

It protects the machine against dust and other solids in the process gas. The inlet filter is available with a polyester cartridge.

### 2.3.3 Oil Mist Separator

To reduce the oil consumption and trap any oil mist, when operating at a high suction pressure, it is recommended to fit an oil mist separator at the discharge connection (OUT).

An oil return line from the oil mist separator to the machine is available in order to retrieve the oil collected by the oil mist separator.

To allow the oil to return to the machine in continuous operation, please comply with the conditions for Continuous Operation [▶ 12].

## 3 Transport

### WARNING

Suspended load.

**Risk of severe injury!**

- Do not walk, stand or work under suspended loads.

### NOTICE

In case the machine is already filled with oil.

**Tilting a machine that is already filled with oil can cause large quantities of oil to ingress into the cylinder. Starting the machine with excessive quantities of oil in the cylinder will immediately break the vanes and ruin the machine!**

- Drain the oil prior to every transport or always horizontally transport the machine.

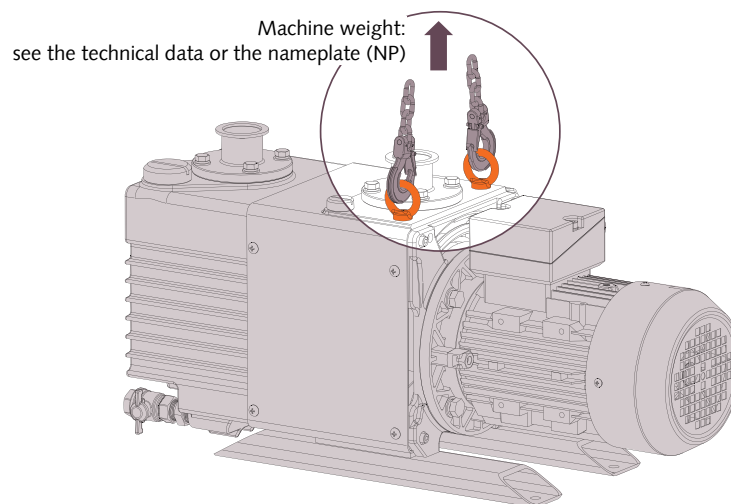

- Check the machine for transport damage.

In case of the machine being secured to a base plate:

- Remove the fixations.

## 4 Storage

- Seal all apertures with adhesive tape or reuse provided caps.

In case of storage of more than 3 months is scheduled:

- Wrap the machine in a corrosion inhibiting film.
- Store the machine indoors, dry, dust free and if possible in original packaging preferably at temperatures between -10 ... 50 °C (14 ... 122 °F), less than 95%RH (relative humidity).

## 5 Installation

### 5.1 Installation Conditions

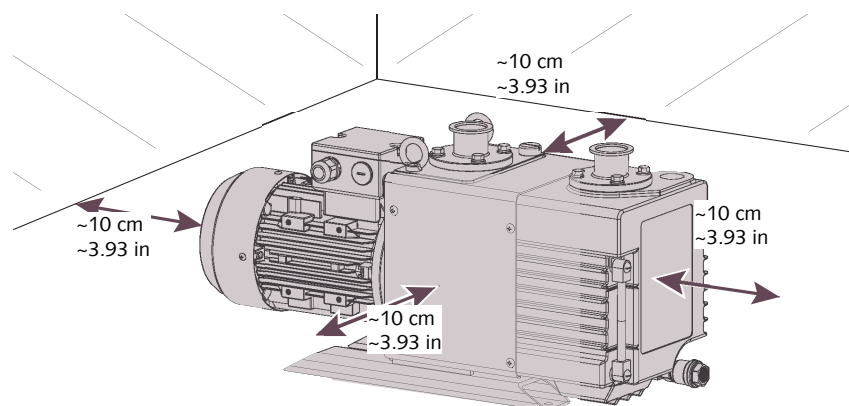

- Make sure that the environment of the machine is not potentially explosive.
- Make sure that the ambient conditions comply with the Technical Data [► 20].
- Make sure that the environmental conditions comply with the protection class of the motor.
- Make sure that the installation space or location is vented such that sufficient cooling of the machine is provided.
- Make sure that cooling air inlets and outlets of the motor fan are not covered or obstructed and that the cooling air flow is not affected adversely in any other way.
- Make sure that the oil level indicator (OLI) remains easily visible.
- Make sure that enough space remains for maintenance work.
- Make sure that the machine is placed or mounted horizontally, a maximum of 1° in any direction.
- Check the oil level, fill up if necessary, see Filling Oil [► 10].
- Make sure that all provided covers, guards, hoods, etc. are mounted.

If the machine is installed at an altitude greater than 1000 meters above sea level:

- Contact your Busch representative, the motor should be derated or the ambient temperature limited.

### 5.2 Connecting Lines / Pipes

- Make sure that the connection lines cause no stress on the machine's connection, if necessary use flexible joints.
- Make sure that the line size of the connection lines over the entire length is at least as large as the connections of the machine.

In case of very long connection lines it is advisable to use larger line sizes in order to avoid a loss of efficiency. Seek advice from your Busch representative.

#### **WARNING**

Internal pressure higher than 300 hPa (gauge).

**Risk of severe injury!**

**Risk of damage to the machine!**

- Make sure that the discharge line is not clogged (either pipe or oil mist separator).

## 5.2.1 Suction Connection

### **WARNING**

Unprotected suction connection.

#### **Risk of severe injury!**

- Do not put hand or fingers in the suction connection.

### **NOTICE**

Intruding foreign objects or liquids.

#### **Risk of damage to the machine!**

In case of the inlet gas contains dust or other foreign solid particles:

- Install a suitable filter (5 micron or less) upstream the machine.

Connection size:

- ISO-KF 40 for RH 0030-0060 B
- ISO-K 63 for RH 0090 B
- VG 40 (without ISO-KF adapter) for RH 0030-0040 B
- VG 50 (without ISO-KF/ISO-K adapter) for RH 0060-0090 B

## 5.2.2 Discharge Connection

### **CAUTION**

The discharge gas contains small quantities of oil.

#### **Risk to health!**

If air is discharged into rooms where persons are present:

- Make sure that sufficient ventilation is provided.

Connection size:

- ISO-KF 40
- VG 40 (without ISO-KF adapter)
- Make sure that the discharged gas will flow without obstruction. Do not shut off or throttle the discharge line or use it as a pressurised air source.

Unless the aspirated air is discharged to the environment right at the machine:

- Make sure that the discharge line either slopes away from the machine or provide a liquid separator or a drip leg with a drain cock, so that no liquids can flow back into the machine.



### 5.2.3 Oil Mist Separator (Optional)

The oil mist separator has to be fitted at the discharge connection.

- Remove the ISO-KF adapter.
- Mount the oil mist separator with its seal and screws.

If there is an oil return line included (optional):

- Connect it from the oil drain port of the oil mist separator to the oil fill plug of the machine (OFP).
- Comply with the conditions for Continuous Operation [▶ 12].
- It is recommended to monitor the internal pressure, see Technical Data [▶ 20].

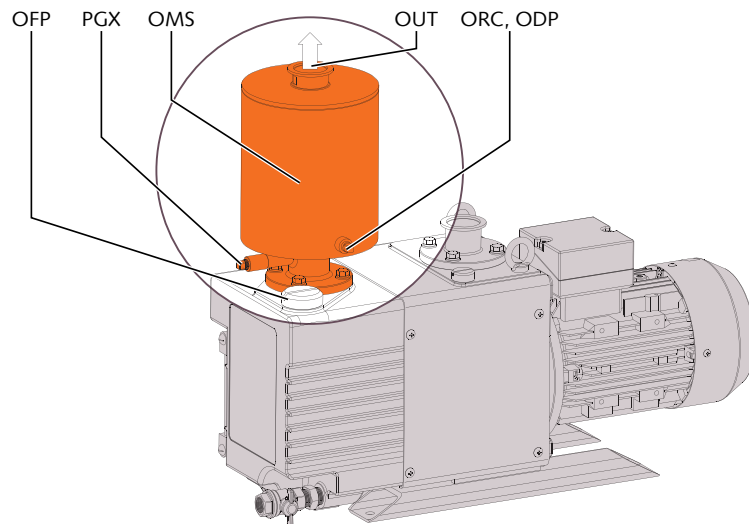

OMS 0040	Oil mist separator for RH 0030 - 0040 B
OMS 0090	Oil mist separator for RH 0060 - 0090 B
ORC / ODP	Oil return line connection / oil drain plug
OFP	Oil fill plug
OUT	Discharge connection
PGX	Pressure gauge connection

## 5.3 Filling Oil

For oil type and oil capacity see Technical Data [▶ 20] and Oil [▶ 20].

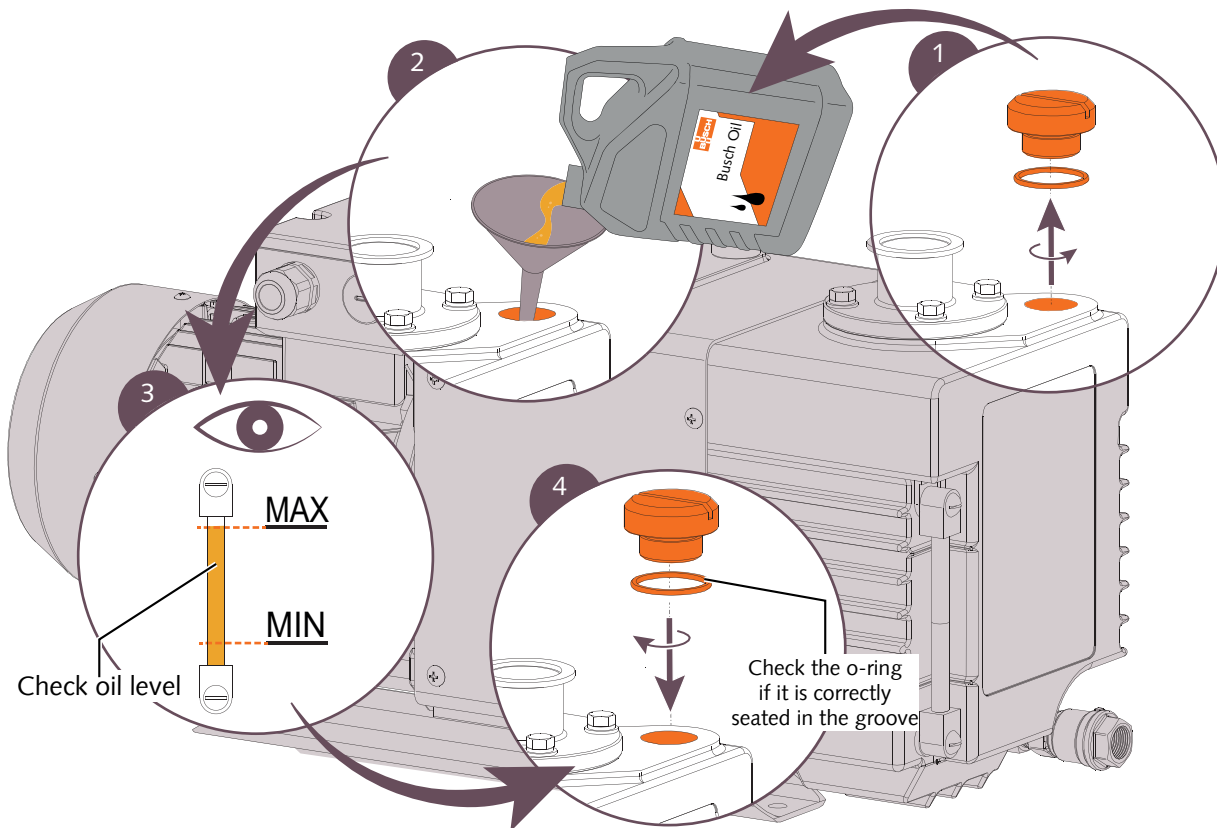

## 5.4 Electrical Connection

### DANGER

Live wires.

#### Risk of electrical shock.

- Electrical installation work must only be executed by qualified personnel.
- Make sure that the power supply for the motor is compatible with the data on the nameplate of the motor.
- Provide an overload protection according to EN 60204-1 for the motor.
- Make sure that the motor of the machine will not be affected by electric or electromagnetic disturbance from the mains; if necessary seek advice from Busch.
- Connect the protective earth conductor.
- Electrically connect the motor.

### NOTICE

Incorrect connection.

#### Risk of damage to the motor!

- The wiring diagrams given below are typical. Check the inside of the terminal box for motor connection instructions/diagrams.

### 5.4.1 Wiring Diagram Three-Phase Motor

- Electrically connect the motor according to the following wiring diagram:

Connector:

- Terminal block (Power supply ► M4 thread; Earth ► M5 thread)

Delta connection (low voltage):

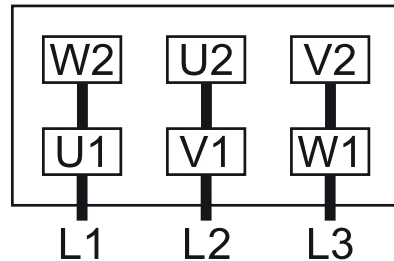

Star connection (high voltage):

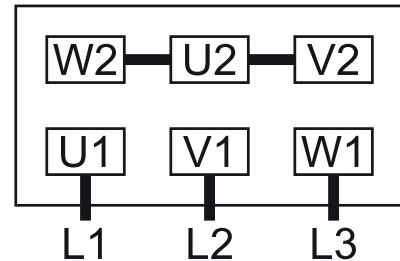

#### ! NOTICE

Incorrect direction of rotation.

#### Risk of damage to the motor!

- Operation in the wrong direction of rotation can destroy the machine in a short time! Prior to starting-up make sure that the machine is operated in the right direction.
- Determine the intended direction of rotation with the arrow (stuck on or cast).
- 'Bump' the motor.

If the rotation must be changed:

- Switch any two of the motor phase wires.

## 6 Commissioning

#### ! NOTICE

The machine is shipped without oil.

#### Operation without oil will ruin the machine in short time!

- Prior to commissioning, the machine must be filled with oil, see Filling Oil [► 10].

#### ⚠ CAUTION

During operation the surface of the machine may reach temperatures of more than 70°C.

#### Risk of burns!

- Avoid contact with the machine during and directly after operation.
- Make sure that the installation conditions (see Installation Conditions [► 7]) are complied with.

If the machine is equipped with a gas ballast valve:

- Make sure that the gas ballast valve is closed before starting the machine.
- Switch on the machine.

- Make sure that the maximum permissible number of starts does not exceed 12 starts per hour.
- After few minutes of operation, check the oil level and top up if necessary.

As soon as the machine is operated under normal operating conditions:

- Measure the motor current and record it as reference for future maintenance and troubleshooting work.

## 6.1 Continuous Operation

### NOTICE

Working at a suction pressure higher than 65 hPa\* in continuous operation.

**Oil will gush out from the exhaust and the machine will run out of oil very quickly!**

**Operation without oil will ruin the machine in short time!**

- Limit the suction pressure in continuous operation.

\* *except for RH 0090 B, the suction pressure is limited at 10 hPa.*

If the machine is equipped with an oil mist separator and an oil return line:

- The operating time in continuous operation is not limited below a suction pressure of 10 hPa for RH 0030-0060 B and 5 hPa for RH 0090 B.

In case of a higher suction pressure:

- The machine must be operated at ultimate pressure for at least 2 minutes once every a few hours.

If there is no oil return line installed:

- Drain manually the oil mist separator regularly from the drain plug.

## 6.2 Conveying Condensable Vapours

Water vapour within the gas flow is tolerated within certain limits. The conveyance of other vapours shall be agreed upon with Busch.

If condensable vapours are to be conveyed:

- Make sure that the gas ballast valve (optional) is open.

Before process:

- Warm up the machine for approximately half an hour.

After process:

- Operate the machine for approximately another half an hour.

# 7 Maintenance



### WARNING

Machines contaminated with hazardous material.

**Risk of poisoning!**

**Risk of infection!**

If the machine is contaminated with hazardous material:

- Wear appropriate personal protective equipment.

 **CAUTION**

Hot surface.

**Risk of burns!**

- Prior to any action requiring touching the machine, let the machine cool down first.
- Shut down the machine and lock against inadvertent start up.
- Vent the connected lines to atmospheric pressure.
- Disconnect all connections.

## 7.1 Maintenance Schedule

The maintenance intervals depend very much on the individual operating conditions. The intervals given below are desired to be considered as starting values which should be shortened or extended as appropriate. Particularly heavy duty operation, such as high dust loads in the environment or in the process gas, other contamination or ingress of process material, can make it necessary to shorten the maintenance intervals significantly.

Interval	Maintenance work
Weekly	<ul style="list-style-type: none"> <li>• Check the level and the colour of the oil.</li> <li>• Check the machine for oil leaks - in case of leaks have the machine repaired (contact Busch).</li> </ul>
Monthly	<ul style="list-style-type: none"> <li>• Check the inlet screen, clean if necessary.</li> </ul> In case of an inlet filter being installed: <ul style="list-style-type: none"> <li>• Check the inlet filter cartridge, replace if necessary.</li> </ul>
After the first 240 hours	<ul style="list-style-type: none"> <li>• Change the oil, see Oil Change [▶ 14].</li> </ul>
At least after 2000 hours	In case of an oil separator being installed: <ul style="list-style-type: none"> <li>• Change the filter cartridge</li> </ul>
Between 6 and 12 months	<ul style="list-style-type: none"> <li>• Change the oil, see Oil Change [▶ 14].</li> </ul> The oil change depends on the process application, refer to the table of Oil Change Recommendations [▶ 13].
Yearly	<ul style="list-style-type: none"> <li>• Clean the machine from dust and dirt.</li> <li>• Check the coupling, see Coupling Maintenance [▶ 15].</li> </ul>
Every 5 years	<ul style="list-style-type: none"> <li>• Have a major overhaul on the machine (contact Busch).</li> </ul>

## 7.2 Oil Change Recommendations

Purpose	Oil Change Interval
Vacuum system for study / laboratory, small vacuum system	Within 6 months to 1 year
Vacuum system for production / vacuum evaporation	Within 3 to 6 months
Vacuum valve exhaust system / large vacuum evaporation system	Within 3 months
Metallurgy vacuum system such as thermal treatment, melting and the like	Within 1 month

Purpose	Oil Change Interval
High vacuum dry / vacuum impregnation / vacuum forming / vacuum packing system	Within 1 month
Low vacuum dry / pug mill / food packing system	Within 1 week

## 7.3 Oil Change

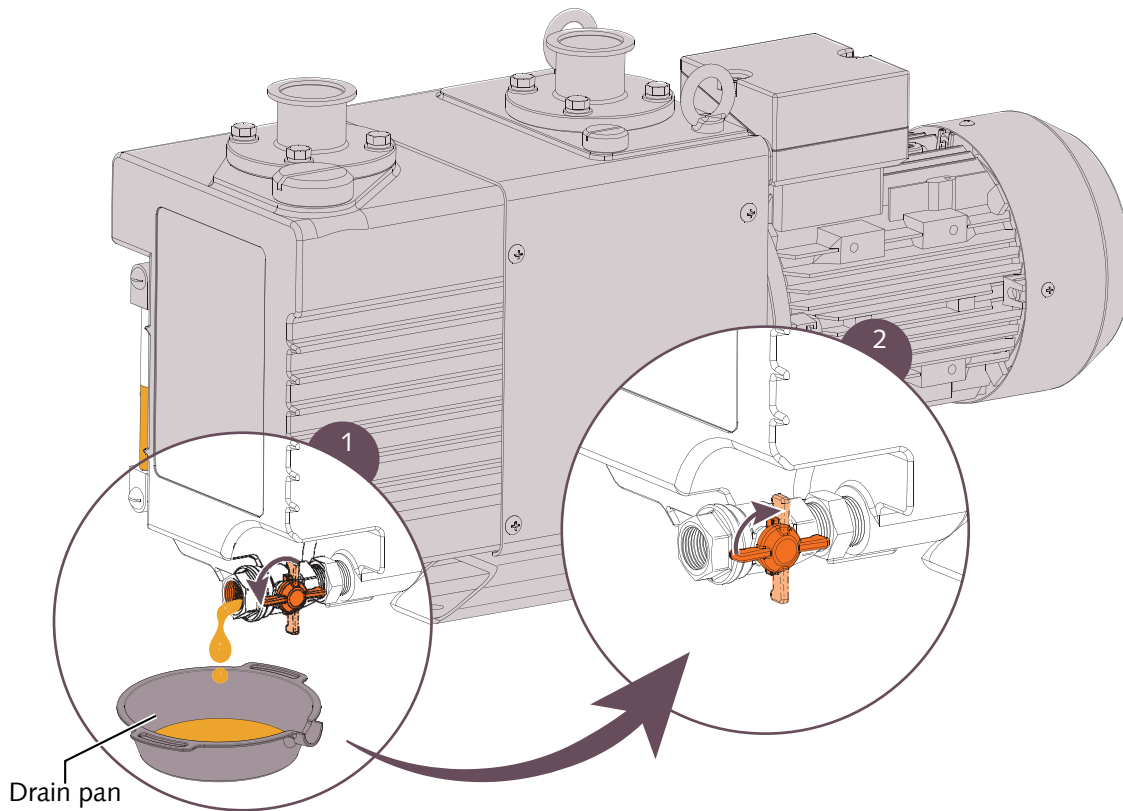

For oil type and oil capacity see Technical Data [▶ 20] and Oil [▶ 20].

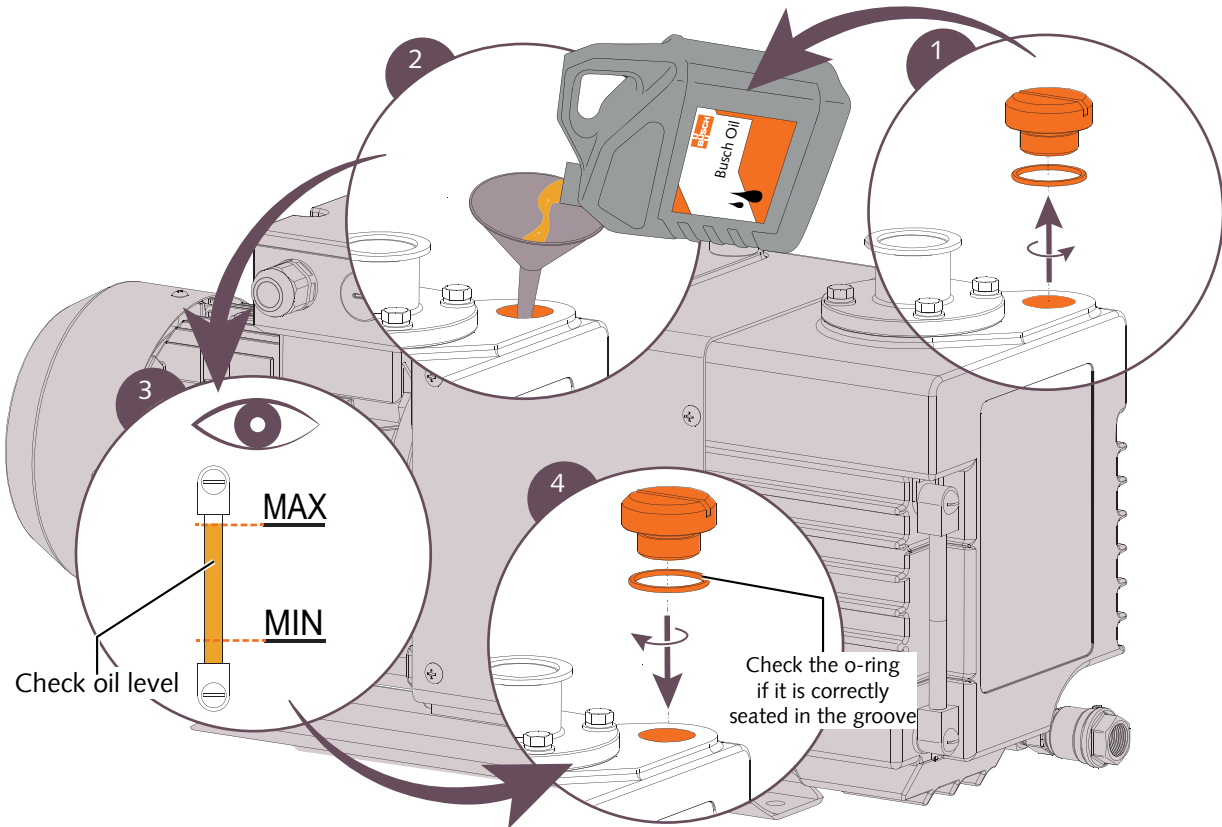

## 7.4 Coupling Maintenance

- Disassemble the machine according to the following illustration.

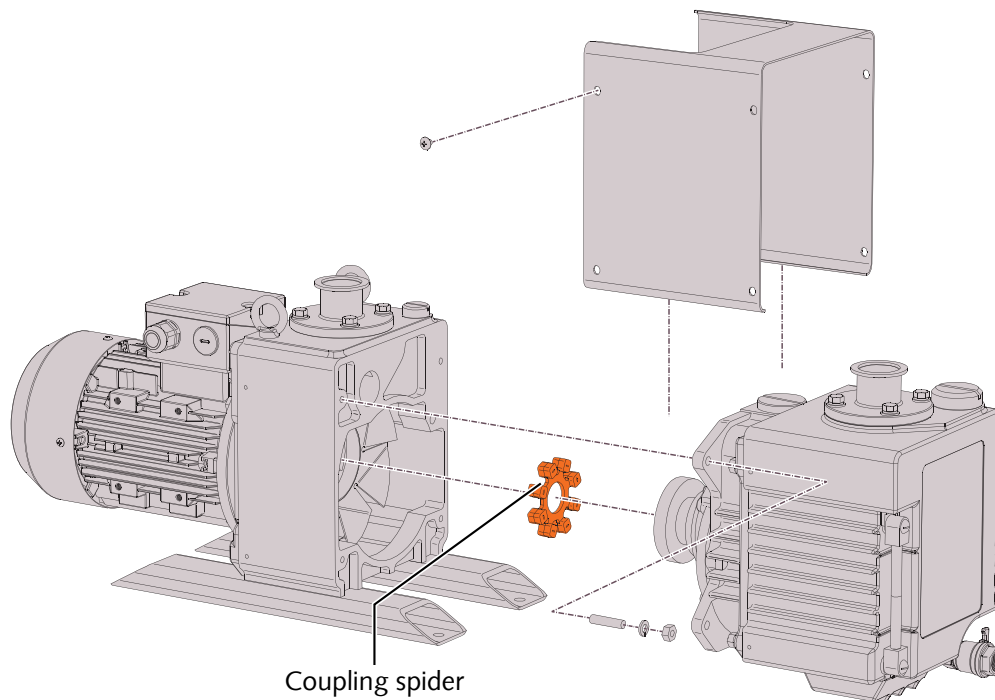

- Check the coupling spider.
- Change it if necessary.
- Reassemble the machine.

## 8 Overhaul

### NOTICE

Improper assembly.

**Risk of premature failure!**

**Loss of efficiency!**

- It is highly recommended that any dismantling of the machine that goes beyond anything that is described in this manual should be done through Busch.



### WARNING

Machines contaminated with hazardous material.

**Risk of poisoning!**

**Risk of infection!**

If the machine is contaminated with hazardous material:

- Wear appropriate personal protective equipment.

In case of the machine having conveyed gas that was contaminated with foreign materials which are dangerous to health:

- Decontaminate the machine as good as possible and state the contamination status in a 'Declaration of Contamination'.

Busch will only accept machines that come with a complete filled in and legally binding signed 'Declaration of Contamination'.

(Form downloadable from [www.buschvacuum.com](http://www.buschvacuum.com))

## 9 Decommissioning

- Shut down the machine and lock against inadvertent start up.
- Vent the connected lines to atmospheric pressure.
- Disconnect all connections.

In case of storage is planned:

- See Storage [▶ 6].

### 9.1 Dismantling and Disposal

- Drain the oil.
- Separate special waste from the machine.
- Dispose of special waste in compliance with applicable regulations.
- Dispose of the machine as scrap metal.



## 10 Spare Parts

### NOTICE

Use of non-Busch genuine spare parts.

**Risk of premature failure!**

**Loss of efficiency!**

- The exclusive use of Busch genuine spare parts and consumables is recommended for the proper function of the machine and for granting of warranty.

Spare parts kit	Description	Part no.
Minor maintenance kit (RH 0030 B)	Includes all the necessary parts for minor maintenance.	0992 168 950
Minor and major maintenance kit (RH 0030 B)	Includes all the necessary parts for a complete overhaul.	0992 168 950+ 0993 168 951
Minor maintenance kit (RH 0040 B)	Includes all the necessary parts for minor maintenance.	0992 168 952
Minor and major maintenance kit (RH 0040 B)	Includes all the necessary parts for a complete overhaul.	0992 168 952 + 0993 168 953
Minor maintenance kit (RH 0060 B)	Includes all the necessary parts for minor maintenance.	0992 168 954
Minor and major maintenance kit (RH 0060 B)	Includes all the necessary parts for a complete overhaul.	0992 168 954 + 0993 168 955
Minor maintenance kit (RH 0090 B)	Includes all the necessary parts for minor maintenance.	0992 168 956
Minor and major maintenance kit (RH 0090 B)	Includes all the necessary parts for a complete overhaul.	0992 168 956 + 0993 168 957

## 11 Accessories

Please contact your Busch representative for accessories list and references.

# 12 Troubleshooting

## DANGER

Live wires.

### Risk of electrical shock.

- Electrical installation work must only be executed by qualified personnel.

## CAUTION

Hot surface.

### Risk of burns!

- Prior to any action requiring touching the machine, let the machine cool down first.

Problem	Possible Cause	Remedy
The machine does not start.	Low ambient temperature.	• Observe the permitted ambient temperature.
	The motor is not supplied with the correct voltage.	• Check the power supply.
	Solid foreign matter has entered the machine.	• Remove the solid foreign matter or repair the machine (contact Busch).
	Internal parts are worn or damaged	• Repair the machine (contact Busch).
	The motor is defective.	• Replace the motor.
	The coupling is defective.	• Replace the coupling.
The machine does not reach the usual pressure on the suction connection.	Oil level too low.	• Top up oil.
	The oil is not circulating.	• Conduct an overhaul (contact Busch).
	Oil has deteriorated.	• Perform a non load operation with vacuum valve closed and gas ballast valve open or replace the oil.
	The inlet screen is partially clogged.	• Clean the inlet screen.
	The inlet filter cartridge (optional) is partially clogged.	• Replace the inlet filter cartridge.
	Measurement method or reading is false.	• Check gauge, check final pressure without installation connected.
	Leak in the system.	• Repair leak.
	Internal parts are worn or damaged.	• Repair the machine (contact Busch).
The machine runs very noisily.	Worn coupling.	• Replace the coupling.
	Oil level too low.	• Top up oil.
	The oil is not circulating.	• Conduct an overhaul (contact Busch)
	Internal parts are worn or damaged.	• Repair the machine (contact Busch).

The machine runs too hot. (Pump surface rise up to about 100 °C (212 °F)).	Continuous operation at too high suction pressure.	<ul style="list-style-type: none"> <li>• Reduce the suction pressure.</li> </ul>
	Insufficient cooling.	<ul style="list-style-type: none"> <li>• Remove dust and dirt from the machine.</li> </ul>
	Ambient temperature too high.	<ul style="list-style-type: none"> <li>• Observe the permitted ambient temperature.</li> </ul>
	Oil level too low.	<ul style="list-style-type: none"> <li>• Top up oil.</li> </ul>
	The oil is not circulating.	<ul style="list-style-type: none"> <li>• Conduct an overhaul (contact Busch).</li> </ul>
	Oil has deteriorated.	<ul style="list-style-type: none"> <li>• Perform a non load operation with vacuum valve closed and gas ballast valve open or replace the oil.</li> </ul>
The machine fumes or expels oil droplets through the gas discharge.	Oil level too high.	<ul style="list-style-type: none"> <li>• Drain the oil until it gets the specified level.</li> </ul>
	Continuous operation is performed at high suction pressure.	<ul style="list-style-type: none"> <li>• Install an oil mist separator.</li> </ul>
	Oil mist separator (optional) is clogged.	<ul style="list-style-type: none"> <li>• Replace the filter element.</li> </ul>
	Oil mist separator (optional) is not assembled properly.	<ul style="list-style-type: none"> <li>• Reassemble properly the oil mist separator.</li> </ul>
The oil is emulsified.	The machine sucked in liquids or significant amounts of vapour.	<ul style="list-style-type: none"> <li>• Perform a non load operation with vacuum valve closed and gas ballast valve open or replace the oil.</li> <li>• Modify the operational mode, (see Conveying Condensable Vapours [► 12]).</li> </ul>

For the solution of problems not mentioned in the troubleshooting chart contact your Busch representative.

## 13 Technical Data

		RH 0030 B	RH 0040 B	RH 0060 B	RH 0090 B
Pumping speed (50Hz / 60Hz)	m <sup>3</sup> /h	24 / 29	33 / 39	55 / 65	80 / 95
	cfm	14.1 / 17.1	19.4 / 23	32.4 / 38.3	47.1 / 55.9
Ultimate total pressure (without gas ballast valve)	hPa (mbar) abs.	6.7 x 10 <sup>-3</sup>			
	Torr abs.	5 x 10 <sup>-3</sup>			
Ultimate total pressure (with gas ballast valve)	hPa (mbar) abs.	2 x 10 <sup>-2</sup>			
	Torr abs.	1.5 x 10 <sup>-2</sup>			
Nominal motor rating (50Hz / 60Hz)	kW	1.5	1.5	2.2	3.7
Nominal motor speed (50Hz / 60Hz)	min <sup>-1</sup>	1500 / 1800	1500 / 1800	1500 / 1800	1500 / 1800
Energy efficiency class		IE3			
Noise level (EN ISO 2151) with oil mist separator (50Hz / 60Hz)	dB(A)	≤ 57 / 61	≤ 60 / 64	≤ 60 / 62	≤ 60 / 66
Water vapour tolerance max. (with gas ballast valve) (50Hz / 60Hz)	hPa (mbar)	13 / 14	13.6 / 17.6	13.2 / 28	9.7 / 28.2 10*
	Torr	9.8 / 10.5	10.2 / 13.2	9.9 / 21	7.3 / 21.2 7.5*
Water vapour capacity (with gas ballast valve) (50Hz / 60Hz)	g / h	190 / 250	270 / 410	430 / 1100	480 / 1650 600*
Ambient temperature range	°C	4 ... 40			
	°F	39 ... 104			
Relative humidity	at 30 °C (86 °F)	80%			
Max. internal pressure	hPa (mbar) gauge	300			
Ambient pressure		Atmospheric pressure			
Cooling method		Air cooled			
Max. oil capacity	l	2.5	2.5	4.0	4.0
	qt	2.6	2.6	4.2	4.2
Weight approx.	kg	58	60	90	113
	lbs	128	132	198	249

\* in continuous operation

## 14 Oil

		VMA 055
Viscosity at 40°C (104°F)		55 cSt (mm <sup>2</sup> /s)
Part number 1 L packaging		0831 169 415
Part number 5 L packaging		0831 169 416

# 15 EU Declaration of Conformity

This Declaration of Conformity and the CE-mark affixed to the nameplate are valid for the machine within the Busch scope of delivery. This Declaration of Conformity is issued under the sole responsibility of the manufacturer. When this machine is integrated into a superordinate machinery the manufacturer of the superordinate machinery (this can be the operating company, too) must conduct the conformity assessment process for the superordinate machine or plant, issue the Declaration of Conformity for it and affix the CE-mark.

The manufacturer

**Busch Produktions GmbH**  
**Schauinslandstr. 1**  
**DE-79689 Maulburg**



declare that the machine(s): **Zebra RH 0030 B; RH 0040 B; RH 0060 B; RH 0090 B**

with a serial number from **1679...** to **1779...** (for RH 0030 B)

with a serial number from **1680...** to **1780...** (for RH 0040 - 0090 B)

has (have) been manufactured in accordance with the European Directives:

- 'Machinery' 2006/42/EC
- 'RoHS' 2011/65/EU, restriction of the use of certain hazardous substances in electrical and electronic equipment

and following the standards.

Standard	Title of the Standard
EN 1012-2:1996 + A1:2009	Compressors and vacuum pumps - Safety requirements - Part 2
EN ISO 2151:2008	Acoustics - Noise test code for compressors and vacuum pumps - Engineering method (grade 2)
IEC/EN 60034-1:2010	Rotating electrical machines - Part 1: Rating and performance
EN 61000-6-2:2005	Electromagnetic compatibility (EMC) - Generic standards. Immunity for industrial environments
EN 61000-6-4:2007 + A1:2011	Electromagnetic compatibility (EMC) - Generic standards. Emission standard for industrial environments
EN ISO 13849-1:2015 <sup>(1)</sup>	Safety of machinery - Safety-related parts of control systems - Part 1: General principles for design

Person authorised to compile the technical file:

Andrej Riwe  
 Busch Produktions GmbH  
 Schauinslandstr. 1  
 DE-79689 Maulburg

Maulburg, 16.03.2016

**Dr.-Ing Karl Busch, General director**

<sup>(1)</sup> In case control systems are integrated.

Note

A large, empty rectangular box with a thin grey border, occupying most of the page below the 'Note' header. It is intended for the user to write their notes.

A large, empty rectangular box with a thin gray border, occupying most of the page. It is intended for writing a note.

# Busch Vacuum Pumps and Systems

All over the World in Industry

**Argentina**

[www.busch-vacuum.com.ar](http://www.busch-vacuum.com.ar)

**Australia**

[www.busch.com.au](http://www.busch.com.au)

**Austria**

[www.busch.at](http://www.busch.at)

**Belgium**

[www.busch.be](http://www.busch.be)

**Brazil**

[www.buschdobrasil.com.br](http://www.buschdobrasil.com.br)

**Canada**

[www.busch.ca](http://www.busch.ca)

**Chile**

[www.busch.cl](http://www.busch.cl)

**China**

[www.busch-china.com](http://www.busch-china.com)

**Colombia**

[www.buschvacuum.co](http://www.buschvacuum.co)

**Czech Republic**

[www.buschvacuum.cz](http://www.buschvacuum.cz)

**Denmark**

[www.busch.dk](http://www.busch.dk)

**Finland**

[www.busch.fi](http://www.busch.fi)

**France**

[www.busch.fr](http://www.busch.fr)

**Germany**

[www.busch.de](http://www.busch.de)

**Hungary**

[www.buschvacuum.hu](http://www.buschvacuum.hu)

**India**

[www.buschindia.com](http://www.buschindia.com)

**Ireland**

[www.busch.ie](http://www.busch.ie)

**Israel**

[www.busch.co.il](http://www.busch.co.il)

**Italy**

[www.busch.it](http://www.busch.it)

**Japan**

[www.busch.co.jp](http://www.busch.co.jp)

**Korea**

[www.busch.co.kr](http://www.busch.co.kr)

**Malaysia**

[www.busch.com.my](http://www.busch.com.my)

**Mexico**

[www.busch.com.mx](http://www.busch.com.mx)

**Netherlands**

[www.busch.nl](http://www.busch.nl)

**New Zealand**

[www.busch.com.au](http://www.busch.com.au)

**Norway**

[www.busch.no](http://www.busch.no)

**Peru**

[www.busch.com.pe](http://www.busch.com.pe)

**Poland**

[www.busch.com.pl](http://www.busch.com.pl)

**Portugal**

[www.busch.pt](http://www.busch.pt)

**Russia**

[www.busch.ru](http://www.busch.ru)

**Singapore**

[www.busch.com.sg](http://www.busch.com.sg)

**South Africa**

[www.busch.co.za](http://www.busch.co.za)

**Spain**

[www.buschiberica.es](http://www.buschiberica.es)

**Sweden**

[www.busch.se](http://www.busch.se)

**Switzerland**

[www.busch.ch](http://www.busch.ch)

**Taiwan**

[www.busch.com.tw](http://www.busch.com.tw)

**Thailand**

[www.busch.co.th](http://www.busch.co.th)

**Turkey**

[www.buschvacuum.com](http://www.buschvacuum.com)

**United Arab Emirates**

[www.busch.ae](http://www.busch.ae)

**United Kingdom**

[www.busch.co.uk](http://www.busch.co.uk)

**USA**

[www.buschusa.com](http://www.buschusa.com)

