

Instruction Manual

COBRA

Dry Screw Vacuum Pumps
NC 1000 B (water-cooled version)

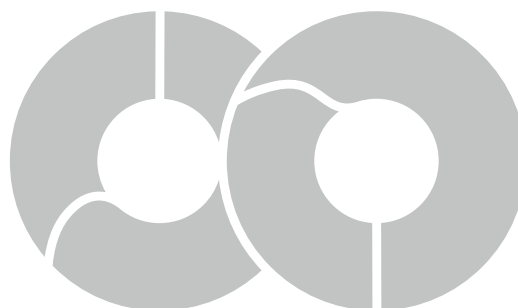

CE

Ateliers Busch S.A.
Zone industrielle, 2906 Chevenez
Switzerland

Table of Contents

- 1 Safety..... 4**
- 2 Product Description 5**
 - 2.1 Operating Principle..... 6
 - 2.2 Application 6
 - 2.3 Standard Features..... 6
 - 2.3.1 Water Cooling 6
 - 2.3.2 Resistance Thermometer..... 6
 - 2.3.3 Level Switch..... 7
 - 2.3.4 Thermometer..... 7
 - 2.3.5 Sealing Systems 7
 - 2.4 Optional Accessories..... 7
 - 2.4.1 Gas Ballast Valve..... 7
 - 2.4.2 Silencer 7
 - 2.4.3 Barrier Gas System 7
 - 2.4.4 Mechanical Seals..... 7
- 3 Transport 8**
- 4 Storage..... 8**
- 5 Installation..... 9**
 - 5.1 Installation Conditions 9
 - 5.2 Connecting Lines / Pipes 9
 - 5.2.1 Suction Connection..... 9
 - 5.2.2 Discharge Connection..... 10
 - 5.2.3 Cooling Water Connection 10
 - 5.2.4 Barrier Gas System Connection (Optional) 11
 - 5.3 Filling Oil..... 12
 - 5.4 Filling Cooling Liquid 14
 - 5.5 Electrical Connection 14
 - 5.5.1 Wiring Diagram Three-Phase Motor (Pump Drive)..... 15
 - 5.6 Electrical Connection of the Monitoring Devices 16
 - 5.6.1 Wiring Diagram Resistance Thermometer 16
 - 5.6.2 Wiring Diagram Level Switch 16
- 6 Commissioning..... 16**
 - 6.1 Conveying Condensable Vapours 17
- 7 Maintenance 18**
 - 7.1 Maintenance Schedule..... 18
 - 7.2 Oil Level Inspection 19
 - 7.3 Cooling Liquid Level Inspection 19
 - 7.4 Replacing the Gas Ballast Filter (Optional) 20
 - 7.5 Oil Change..... 20
 - 7.6 Cooling Liquid Change 23
- 8 Overhaul..... 24**
- 9 Decommissioning 25**
 - 9.1 Dismantling and Disposal..... 25
- 10 Spare Parts 25**
- 11 Troubleshooting..... 26**
- 12 Technical Data 28**

13 Cooling Liquid	28
14 Oil	28
15 EU Declaration of Conformity	29

1 Safety

Prior to handling the machine, this instruction manual should be read and understood. If anything needs to be clarified, please contact your Busch representative.

Read this manual carefully before use and keep for future reference.

This instruction manual remains valid as long as the customer does not change anything on the product.

The machine is intended for industrial use. It must be handled only by technically trained personnel.

Always wear appropriate personal protective equipment in accordance with the local regulations.

The machine has been designed and manufactured according to state-of-the-art methods. Nevertheless, residual risks may remain. This instruction manual highlights potential hazards where appropriate. Safety notes and warning messages are tagged with one of the keywords DANGER, WARNING, CAUTION, NOTICE and NOTE as follows:

DANGER

... indicates an imminent dangerous situation that will result in death or serious injuries if not prevented.

WARNING

... indicates a potentially dangerous situation that could result in death or serious injuries.

CAUTION

... indicates a potentially dangerous situation that could result in minor injuries.

NOTICE

... indicates a potentially dangerous situation that could result in damage to property.

NOTE

... indicates helpful tips and recommendations, as well as information for efficient and trouble-free operation.

2 Product Description

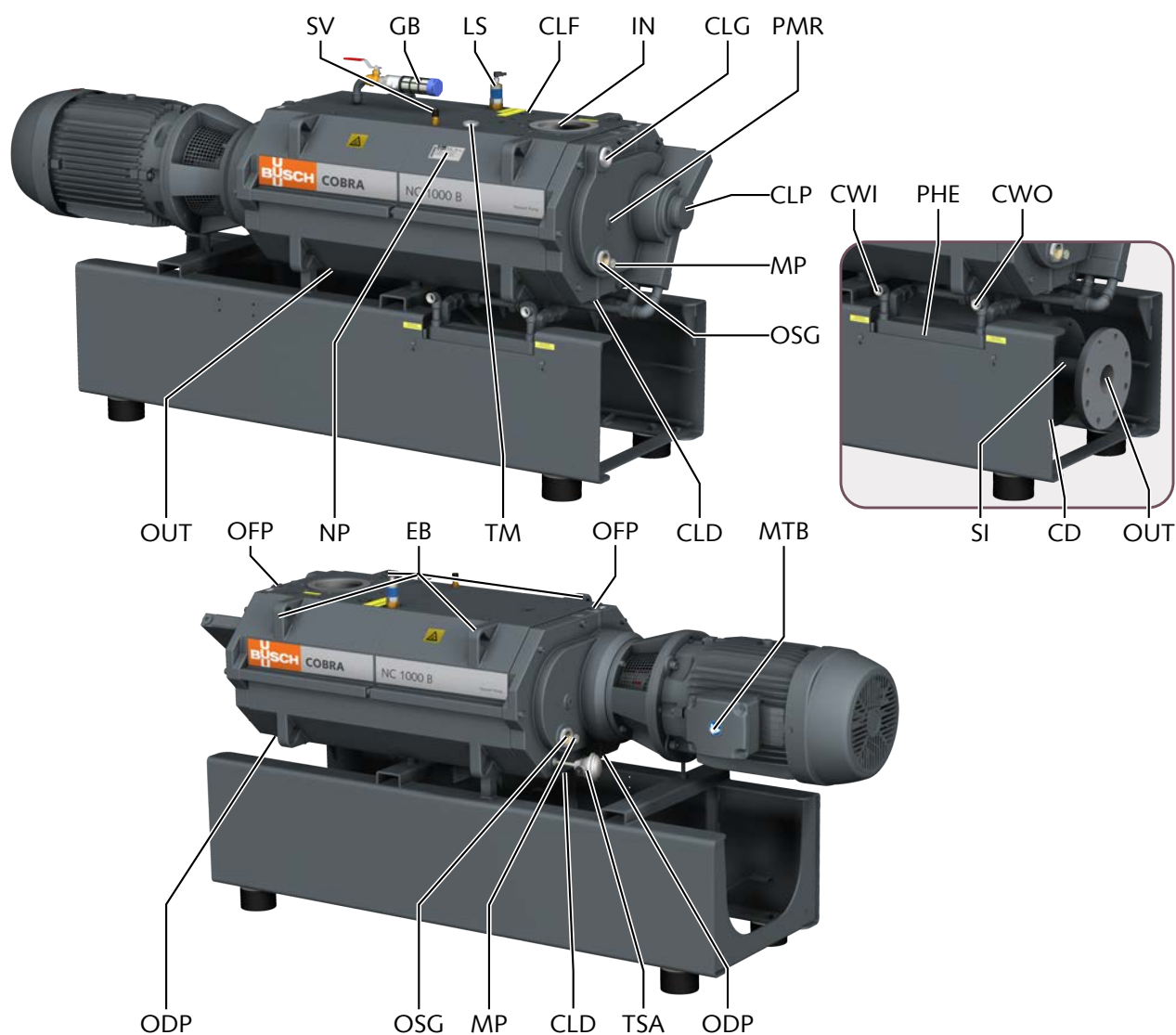

CD	Condensate drain	CLD	Cooling liquid drain plug
CLF	Cooling liquid fill plug	CLG	Cooling liquid sight glass
CLP	Cooling liquid pump	CWI	Cooling water inlet
CWO	Cooling water outlet	EB	Eye bolt
GB	Gas ballast valve	IN	Suction connection
LS	Level switch	MP	Magnetic plug
MTB	Motor terminal box	NP	Nameplate
ODP	Oil drain plug	OFF	Oil fill plug
OSG	Oil sight glass	OUT	Discharge connection
PHE	Plate heat exchanger	PMR	Plug for manual rotation of rotors
SI	Silencer	SV	Safety valve
TM	Thermometer	TSA	Resistance thermometer

NOTE

Technical term.

In this instruction manual, we consider that the term 'machine' refers to the 'vacuum pump'.

2.1 Operating Principle

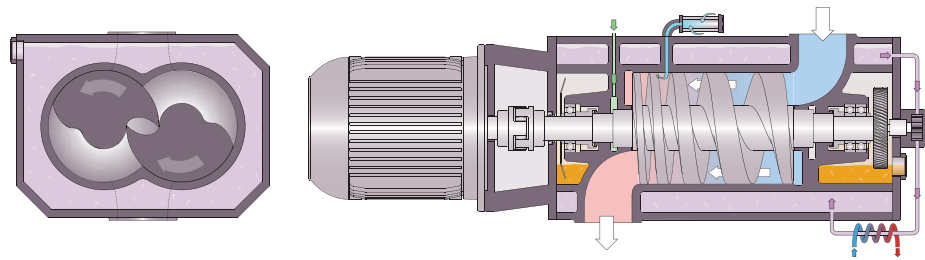

The machine works on the one-stage, twin-screw pump principle.

Two screw rotors are rotating inside the cylinder. The pumping medium is trapped between the individual screw coils, compressed and transported to the gas discharge. During the compression process, the two screw rotors do not come into contact with each other nor with the cylinder. There is no need for a lubrication or an operating fluid in the process chamber.

2.2 Application

The machine is intended for the suction of air and other dry, non-aggressive, non-toxic and non-explosive gases.

Conveying of other media leads to an increased thermal and/or mechanical load on the machine and is permissible only after a consultation with Busch.

The machine is intended for the placement in a non-potentially explosive environment.

The machine is capable of maintaining ultimate pressure.

The machine is suitable for continuous operation.

Permitted environmental conditions see Technical Data [[▶ 28](#)].

2.3 Standard Features

2.3.1 Water Cooling

The machine is cooled by a cooling liquid circuit in the cylinder cover and cylinder.

The cooling liquid pump (CLP) allows a recirculating flow in the cooling liquid chamber.

The cooling liquid is cooled by a plate heat exchanger (PHE) which must be connected to the water main.

2.3.2 Resistance Thermometer

The resistance thermometer monitors the cooling liquid temperature of the machine.

A trip signal must be set. The machine must be stopped when the cooling liquid temperature reaches 70 °C.

2.3.3 Level Switch

The level switch monitors the cooling liquid level in the cylinder.

The machine must be stopped when the cooling liquid level is too low.

2.3.4 Thermometer

The thermometer allows a visual display of the cooling liquid temperature.

2.3.5 Sealing Systems

The machine is equipped with labyrinth seals on the motor side and suction side.

Other sealing systems are optionally available, see Mechanical Seals [► 7].

Sealing systems prevent the process gas going to the bearings chambers.

Depending on the application, the sealing systems efficiency can be improved with a barrier gas system, see Barrier Gas System [► 7].

2.4 Optional Accessories

2.4.1 Gas Ballast Valve

The gas ballast valve mixes the process gas with a limited quantity of ambient air to counteract the condensation of vapour inside the machine.

The gas ballast valve has an influence on the ultimate pressure of the machine, see Technical Data [► 28].

A ball valve enables to open or close the gas ballast flow.

2.4.2 Silencer

A silencer at the discharge connection (OUT) can be provided to reduce the exhaust gas noise.

2.4.3 Barrier Gas System

The barrier gas system allows the supply of compressed air or nitrogen into the motor side shaft seals in order to improve the sealing efficiency.

2.4.4 Mechanical Seals

The sealing systems can be equipped with mechanical seals. The following variants are possible:

- Oil lubricated single mechanical seals on the motor side and labyrinth seals on the suction side.
- Oil lubricated single mechanical seals on the motor side and suction side.

3 Transport

WARNING

Suspended load.

Risk of severe injury!

- Do not walk, stand or work under suspended loads.

NOTICE

In case the machine is already filled with oil.

Tilting a machine that is already filled with oil can cause large quantities of oil to ingress into the cylinder.

- Drain the oil prior to every transport or always horizontally transport the machine.

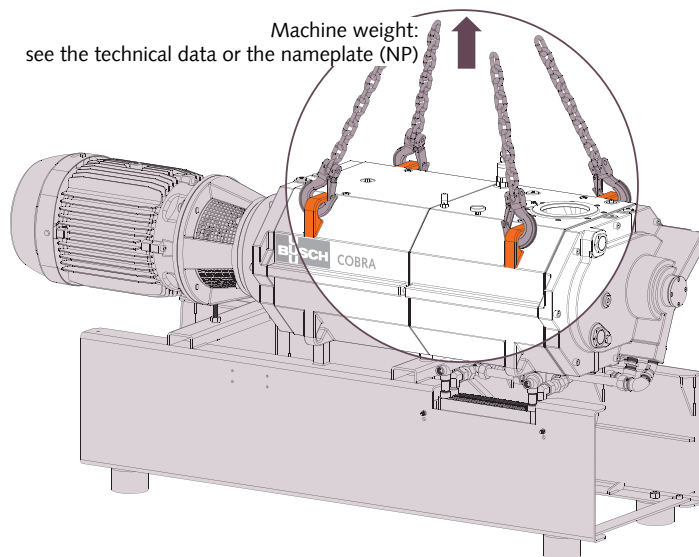

WARNING

Lifting the machine using the motor eye bolt.

Risk of severe injury!

- Do not lift the machine using the eye bolt fitted to the motor. Only lift the machine as previously shown.

- Check the machine for transport damage.

If the machine is secured to a base plate:

- Remove the machine from the base plate.

4 Storage

- Seal all apertures with adhesive tape or reuse provided caps.

If the machine is to be stored for more than 3 months:

- Wrap the machine in a corrosion inhibiting film.
- Store the machine indoors, dry, dust free and if possible in original packaging preferably at temperatures between 5 ... 55 °C.

5 Installation

5.1 Installation Conditions

- Make sure that the environment of the machine is not potentially explosive.
- Make sure that the ambient conditions comply with the Technical Data [► 28].
- Make sure that the environmental conditions comply with the protection class of the motor.
- Make sure that the installation space or location is vented such that sufficient cooling of the machine is provided.
- Make sure that cooling air inlets and outlets of the motor fan are not covered or obstructed and that the cooling air flow is not affected adversely in any other way.
- Make sure that the oil sight glass (OSG) remains easily visible.
- Make sure that enough space remains for maintenance work.
- Make sure that the machine is placed or mounted horizontally, a maximum of 1° in any direction.
- Check the oil level, see Oil Level Inspection [► 19].
- Check the cooling liquid level, fill up if necessary, see Filling Cooling Liquid [► 14].
- Make sure that the cooling water complies with the requirements, see Cooling Water Connection [► 10].

If the machine is installed at an altitude greater than 1000 meters above sea level:

- Contact your Busch representative, the motor should be derated or the ambient temperature limited.

5.2 Connecting Lines / Pipes

- Make sure that the connection lines cause no stress on the machine's connection; if necessary use flexible joints.
- Make sure that the line size of the connection lines over the entire length is at least as large as the connections of the machine.

In case of very long connection lines it is advisable to use larger line sizes in order to avoid a loss of efficiency. Seek advice from your Busch representative.

5.2.1 Suction Connection

WARNING

Unprotected suction connection.

Risk of severe injury!

- Do not put hand or fingers in the suction connection.

NOTICE

Intruding foreign objects or liquids.

Risk of damage to the machine!

If the inlet gas contains dust or other foreign solid particles:

- Install a suitable filter (5 micron or less) upstream from the machine.

Connection size:

- DN125 PN16, EN 1092-1

If the machine is used as part of a vacuum system:

- Busch recommends the installation of an isolation valve in order to prevent the machine from turning backwards.

5.2.2 Discharge Connection

Connection size:

At the machine discharge connection:

- DN125 PN16, EN 1092-1

At the silencer (SI) discharge connection (two optional versions available):

- DN125 PN16, EN 1092-1
- DN100 ISO-K, DIN 28404

- Make sure that the discharged gas will flow without obstruction. Do not shut off or throttle the discharge line or use it as a pressurised air source.
- Make sure that the counter pressure at the discharge connection (OUT) does not exceed the admissible pressure, see Technical Data [► 28].

5.2.3 Cooling Water Connection

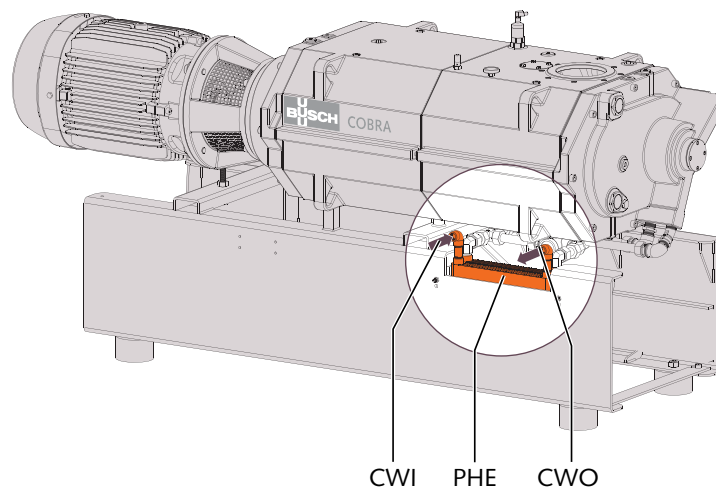

CWI Cooling water inlet

CWO Cooling water outlet

PHE Plate heat exchanger

Connection size:

- G1/2, ISO 228-1 (CWI / CWO)

- Make sure that the cooling water complies with the following requirements:

Supply capacity	l/min	15
Water pressure	bar	1 ... 6
Supply temperature	°C	+5 ... +30
Required pressure differential across supply and return	bar	≥ 1

- To reduce the maintenance effort and ensure a long product lifetime we recommend the following cooling water quality:

Hardness	mg/l (ppm)	< 90
Properties	Clean & clear	
PH value		7 ... 8

Particle size	μm	< 200
Chloride	mg/l	< 100
Electrical conductivity	$\mu\text{S/cm}$	≤ 100
Free chloride	mg/l	< 0.3
Materials in contact with the cooling water	Stainless steel	

i NOTE

Water hardness unit conversion.

1 mg/l (ppm) = 0.056 °dh (german degree) = 0.07 °e (english degree) = 0.1 °fH (french degree)

5.2.4 Barrier Gas System Connection (Optional)

Without nitrogen panel

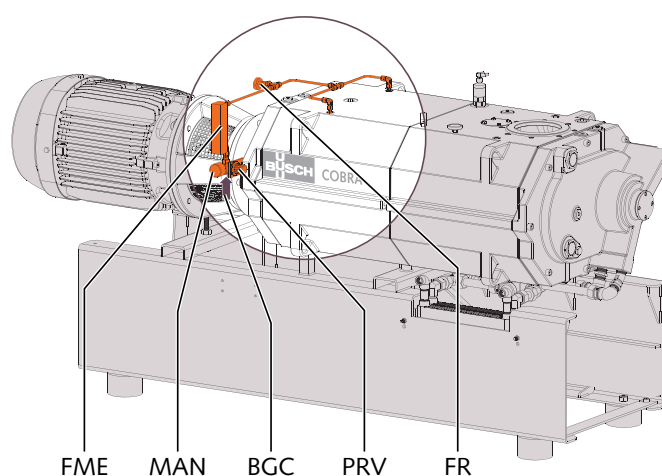

BGC	Barrier gas connection	FME	Flow meter
FR	Flow regulator	MAN	Manometer
PRV	Pressure regulating valve		

Connection size:

– G1/4, ISO 228-1

- Make sure that the gas complies with the following requirements:

Gas type	Dry nitrogen or air	
Gas temperature	°C	0 ... 60
Maximum gas pressure	bar	13
Recommended pressure setting at the pressure regulating valve (PRV)	bar	3
Filtration	μm	5
Recommended flow rate	SLM*	30
Air quality (only for air)	Acc. to ISO 8573-1	Class 5.4.4.

* standard litre per minute

5.3 Filling Oil

! NOTICE

Use of an inappropriate oil.

Risk of premature failure!

Loss of efficiency!

- Only use an oil type which has previously been approved and recommended by Busch.

For oil type and oil capacity see Technical Data [▶ 28] and Oil [▶ 28].

Oil filling at the motor side

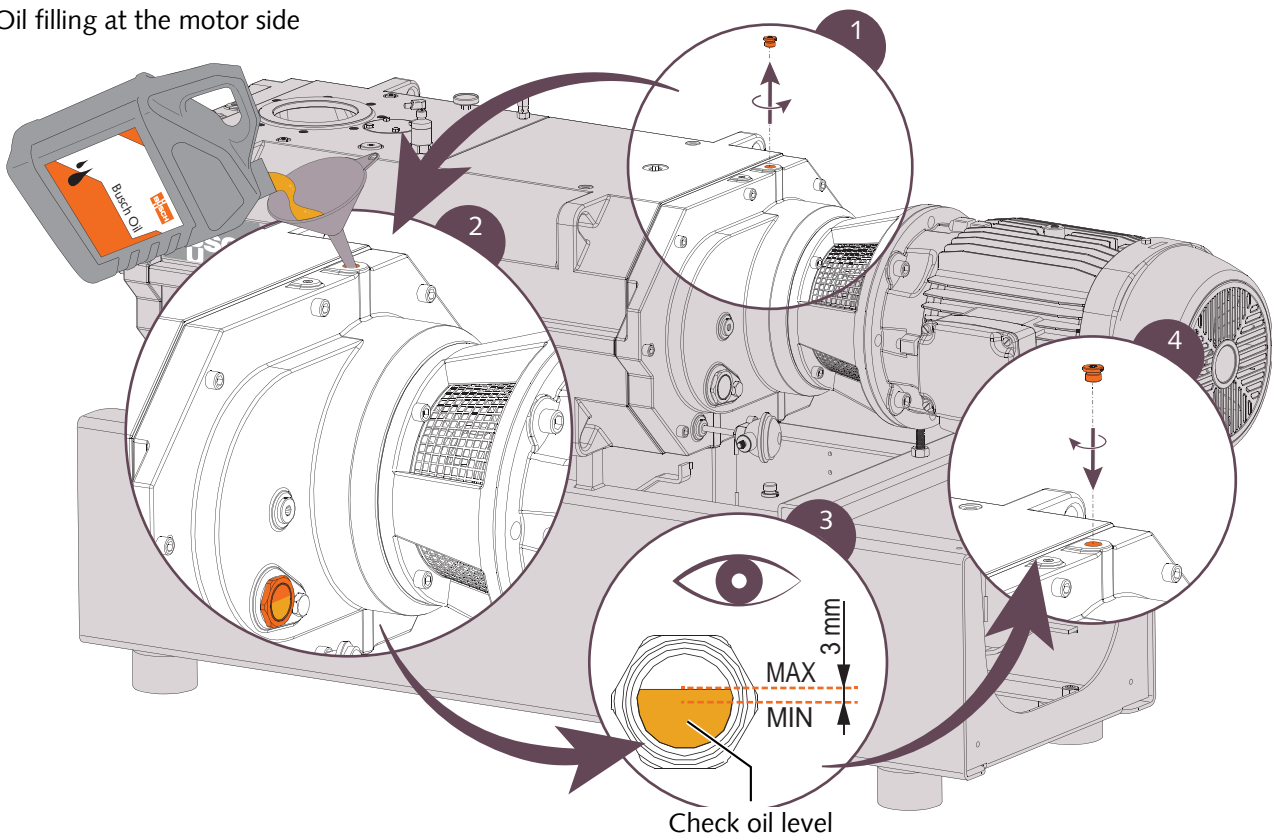

Oil filling at the suction side

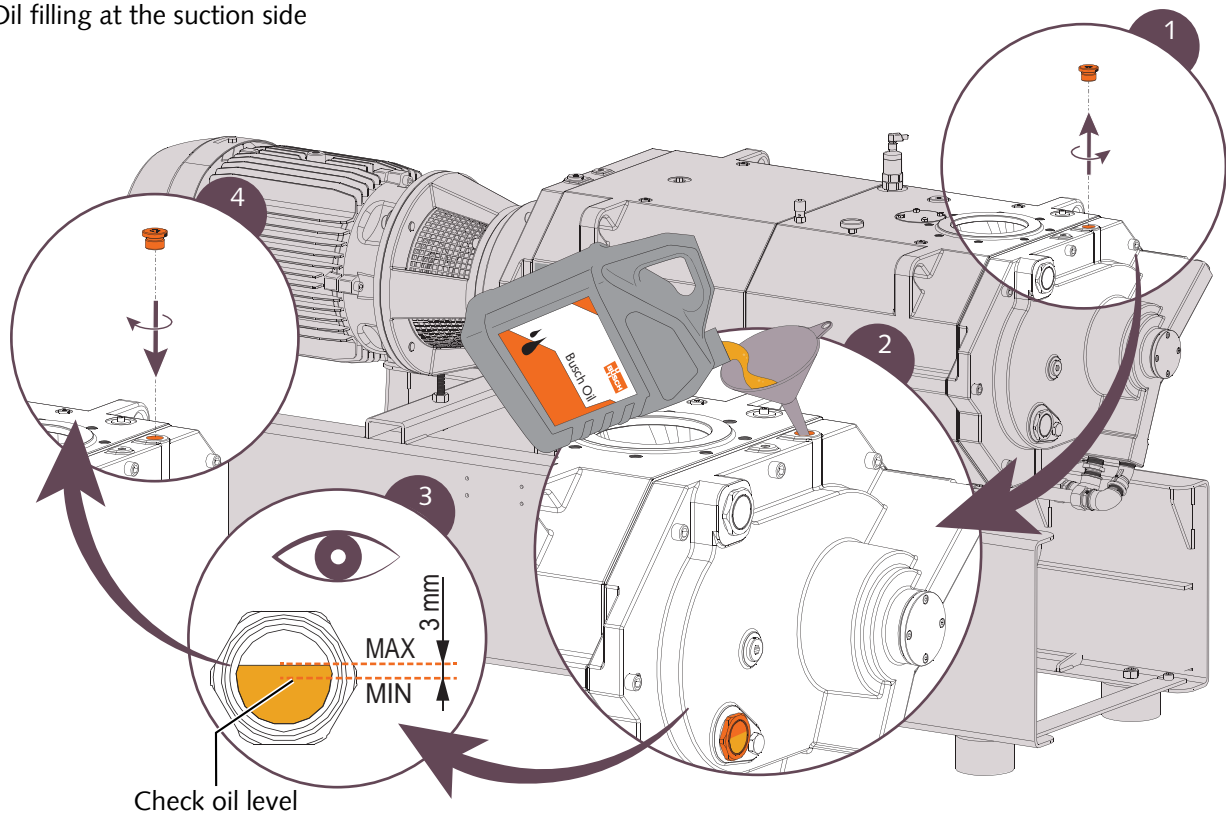

When the oil filling is achieved:

- Write down the oil change date on the sticker.

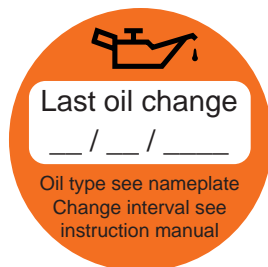

If there is no sticker on the pump:

- Order it from your Busch representative.

5.4 Filling Cooling Liquid

For cooling liquid type and cooling liquid capacity see Technical Data [▶ 28] and Cooling Liquid [▶ 28].

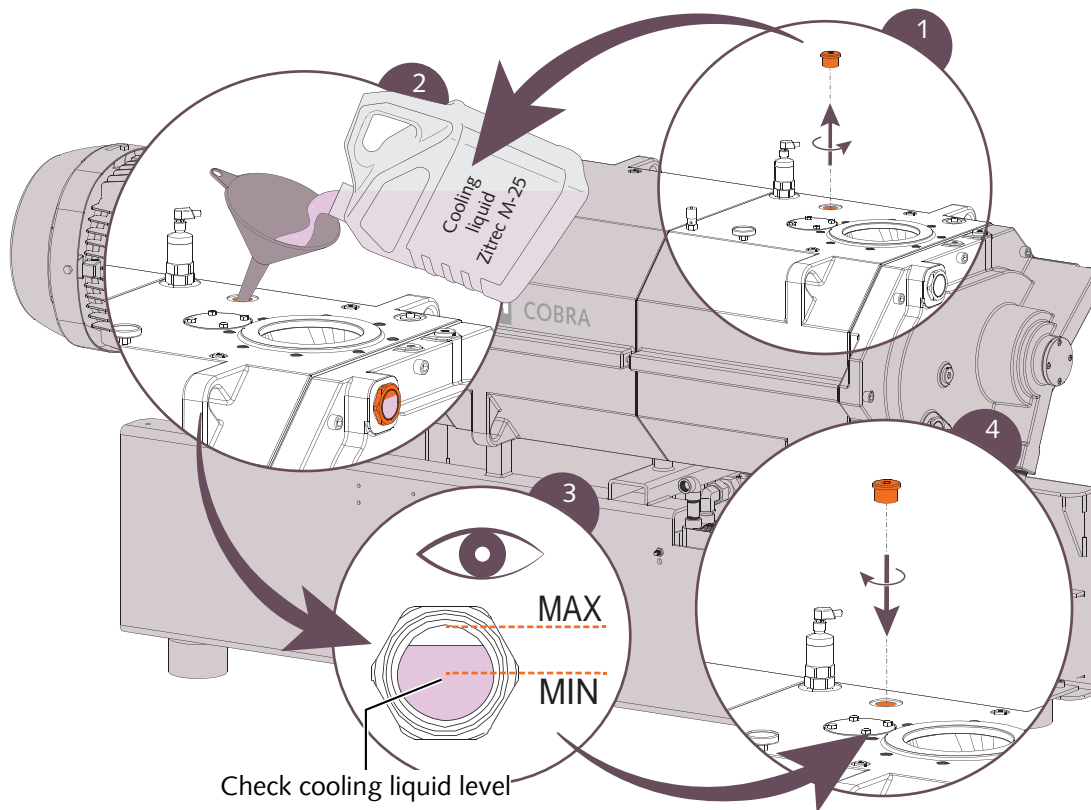

5.5 Electrical Connection

DANGER

Live wires.

Risk of electrical shock.

- Electrical installation work must only be executed by qualified personnel.
- Make sure that the power supply for the motor is compatible with the data on the nameplate of the motor.
- Provide overload protection according to EN 60204-1 for the motor.
- Make sure that the motor of the machine will not be affected by electric or electromagnetic disturbance from the mains; if necessary seek advice from Busch.
- Connect the protective earth conductor.
- Electrically connect the motor.

! NOTICE

The admissible motor nominal speed exceeds the recommendation.

Risk of damage to the machine!

- Check the admissible motor nominal speed (n_{\max}) on the nameplate of the machine (NP).
- Make sure to comply with it.
- Consult the Technical Data [► 28] to get more information.

! NOTICE

The motor frequency is below 30 Hz.

Risk of damage to the machine!

- The motor nominal speed must always be higher than 1800 min^{-1} (30 Hz).

! NOTICE

Incorrect connection.

Risk of damage to the motor!

- The wiring diagrams given below are typical. Check the inside of the terminal box for motor connection instructions/diagrams.

5.5.1 Wiring Diagram Three-Phase Motor (Pump Drive)

Delta connection (low voltage):

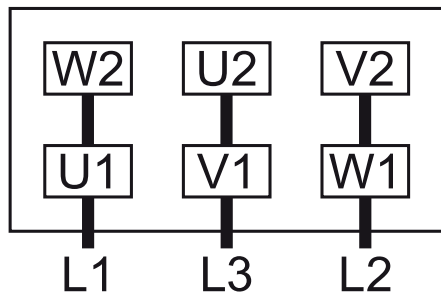

Star connection (high voltage):

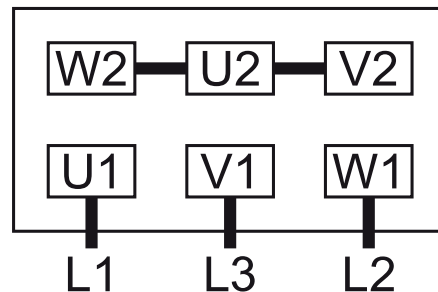
**! NOTICE**

Incorrect direction of rotation.

Risk of damage to the machine!

- Operation in the wrong direction of rotation can destroy the machine in a short time! Prior to start-up, ensure that the machine is operated in the right direction.

The intended rotation direction of the motor is defined by the illustration below:

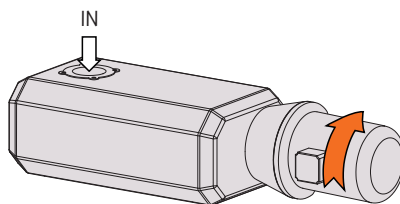

- Jog the motor briefly.

- Watch the fan wheel of the motor and determine the direction of rotation just before the fan wheel stops.

If the rotation of the motor must be changed:

- Switch any two of the motor phase wires.

5.6 Electrical Connection of the Monitoring Devices

NOTE

In order to prevent potential nuisance alarms, Busch recommends that the control system is configured with a time delay of at least 10 seconds.

5.6.1 Wiring Diagram Resistance Thermometer

Part no.: 0651 552 252

Connector: M12x1, 4-pin

$U = 7.5 \dots 30 \text{ VDC}$

$4 \dots 20 \text{ mA} \blacktriangleright -50 \dots 150 \text{ }^\circ\text{C}$

Trip signal: $T_{\text{trip}}: 70 \text{ }^\circ\text{C}$

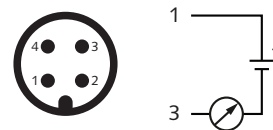

1 = Brown ; 3 = Blue

5.6.2 Wiring Diagram Level Switch

Part no.: 0652 569 236

Connector: M12x1, 4-pin

$U = 10 \dots 30 \text{ VDC (DC-PNP)}$

$I_{\text{max}} = 200 \text{ mA}$

Contact: Normally closed

Switch point:

$L_{\text{trip}} \blacktriangleright$ pin 1 + 4 \blacktriangleright low level "stop the machine"

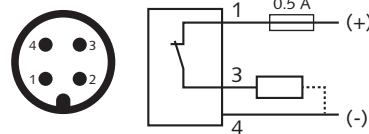

1 = Brown ; 3 = Blue ; 4 = Black

6 Commissioning

NOTICE

The machine is shipped without oil.

Operation without oil will ruin the machine in short time!

- Prior to commissioning, the machine must be filled with oil, see Filling Oil [[▶ 12](#)].

NOTICE

Lubricating a dry running machine (process chamber).

Risk of damage to the machine!

- Do not lubricate the process chamber of the machine with oil or grease.

CAUTION

During operation the surface of the machine may reach temperatures of more than 70°C.

Risk of burns!

- Avoid contact with the machine during and directly after operation.



CAUTION

Noise of running machine.

Risk of damage to hearing!

If persons are present in the vicinity of a non noise insulated machine over extended periods:

- Make sure that ear protection is being used.
- Make sure that the installation conditions (see Installation Conditions [► 9]) are complied with.
- Open the water supply.

If the machine is equipped with a barrier gas system:

- Open the barrier gas supply.
- Adjust the barrier gas pressure and volume flow.
- Switch on the machine.
- Make sure that the maximum permissible number of starts does not exceed 6 starts per hour.
- After few minutes of operation, perform an Oil Level Inspection [► 19].
- After few minutes of operation, perform a Cooling Liquid Level Inspection [► 19].

As soon as the machine is operated under normal operating conditions:

- Measure the motor current and record it as reference for future maintenance and troubleshooting work.

6.1 Conveying Condensable Vapours

The machine, equipped either with a gas ballast valve or a dilution gas system, is suitable for the conveyance of condensable vapours within the gas flow.

If condensable vapours are to be conveyed:

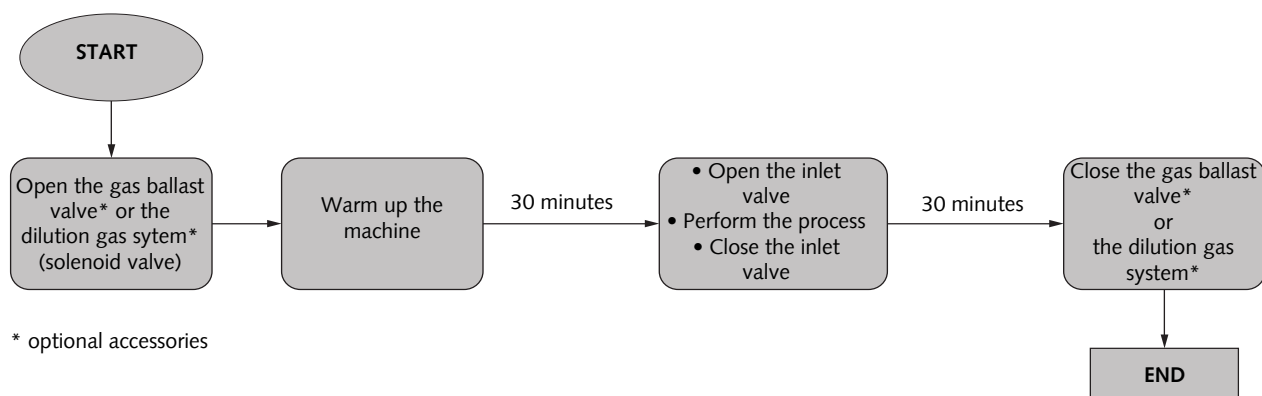

- Continuously drain condensate from the condensate drain plug (CD) of the silencer (SI) (Optional).

7 Maintenance



 **WARNING**

Machines contaminated with hazardous material.

Risk of poisoning!

Risk of infection!

If the machine is contaminated with hazardous material:

- Wear appropriate personal protective equipment.

 **CAUTION**

Hot surface.

Risk of burns!

- Prior to any action requiring touching the machine, let the machine cool down first.

- Shut down the machine and lock against inadvertent start up.
- Turn off the water supply.

If the machine is equipped with a barrier gas system:

- Close the barrier gas supply.
- Vent the connected lines to atmospheric pressure.

If necessary:

- Disconnect all connections.

7.1 Maintenance Schedule

The maintenance intervals depend very much on the individual operating conditions. The intervals given below are desired to be considered as starting values which should be shortened or extended as appropriate. Particularly heavy duty operation, such as high dust loads in the environment or in the process gas, other contamination or ingress of process material, can make it necessary to shorten the maintenance intervals significantly.

Interval	Maintenance work
Monthly	<ul style="list-style-type: none"> • Check the oil level, see Oil Level Inspection [▶ 19]. • Check the cooling liquid level, see Cooling Liquid Level Inspection [▶ 19]. • Check the machine for oil leaks - in case of leaks have the machine repaired (contact Busch).
Yearly	<ul style="list-style-type: none"> • Carry out a visual inspection and clean the machine from dust and dirt. • Check the electrical connections and the monitoring devices.
Yearly In case of those accessories being installed.	<ul style="list-style-type: none"> • Check the filter of the gas ballast valve (GB) and change it if necessary, see Replacing the Gas Ballast Filter (Optional) [▶ 20]. • Check the silence (SI) and clean it if necessary.

Every 5000 hours, at the latest after 1 year	<ul style="list-style-type: none"> • Change the oil of the gear and bearing housings (both sides), see Oil Change [▶ 20]. • Change the cooling liquid, see Cooling Liquid Change [▶ 23]. • Clean the magnetic plugs (MP).
Every 16000 hours, at the latest after 4 years	<ul style="list-style-type: none"> • Have a major overhaul on the machine (contact Busch).

7.2 Oil Level Inspection

- Shut down the machine.
- When the machine is stopped, wait 1 minute before checking the oil level.

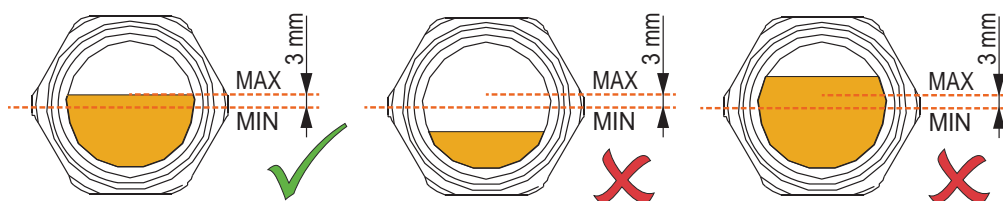

- Make sure that the oil level is between the middle of the oil sight glass and 3mm above it.
- Fill up if necessary, see Oil Filling [▶ 12].

7.3 Cooling Liquid Level Inspection

- Shut down the machine.

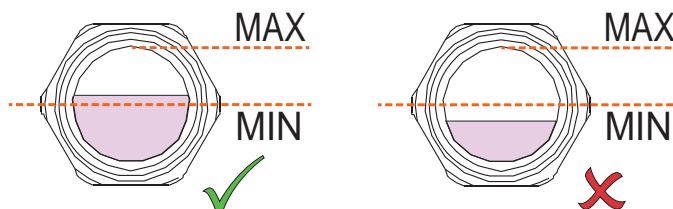

- Fill up if necessary, see Filling Cooling Liquid [▶ 14].

7.4 Replacing the Gas Ballast Filter (Optional)

Busch genuine spare parts
Gas ballast filter: part no. 0562 550 434

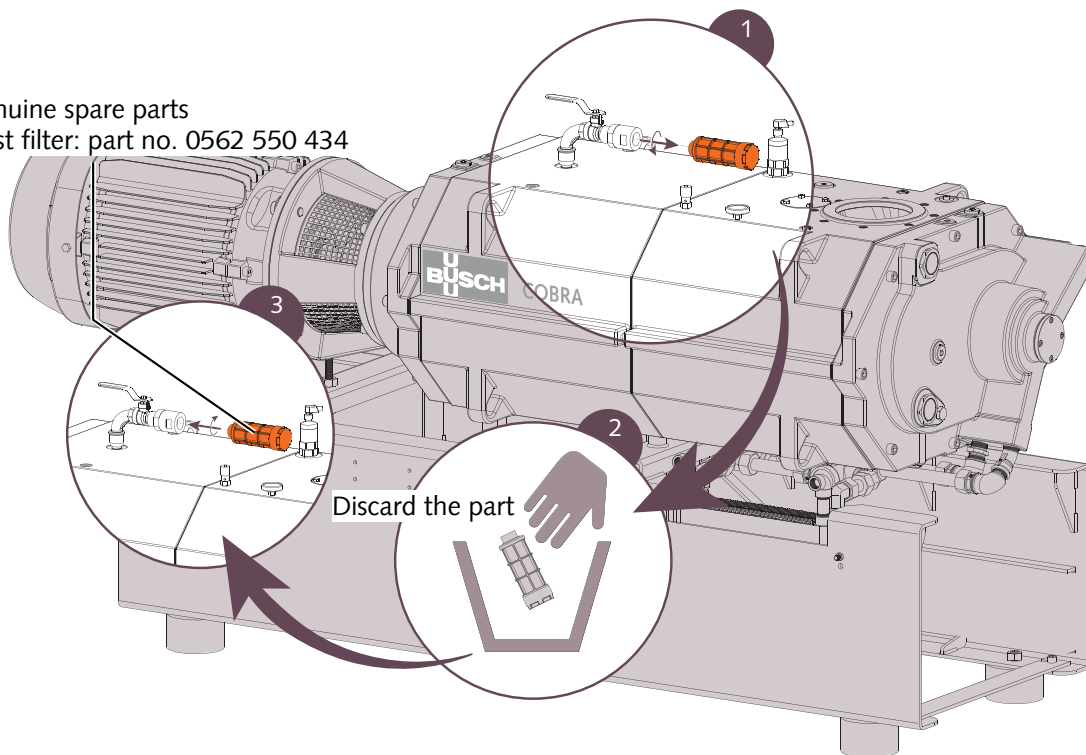

7.5 Oil Change

! NOTICE

Use of an inappropriate oil.

Risk of premature failure!

Loss of efficiency!

- Only use an oil type which has previously been approved and recommended by Busch.

Oil draining at the motor side

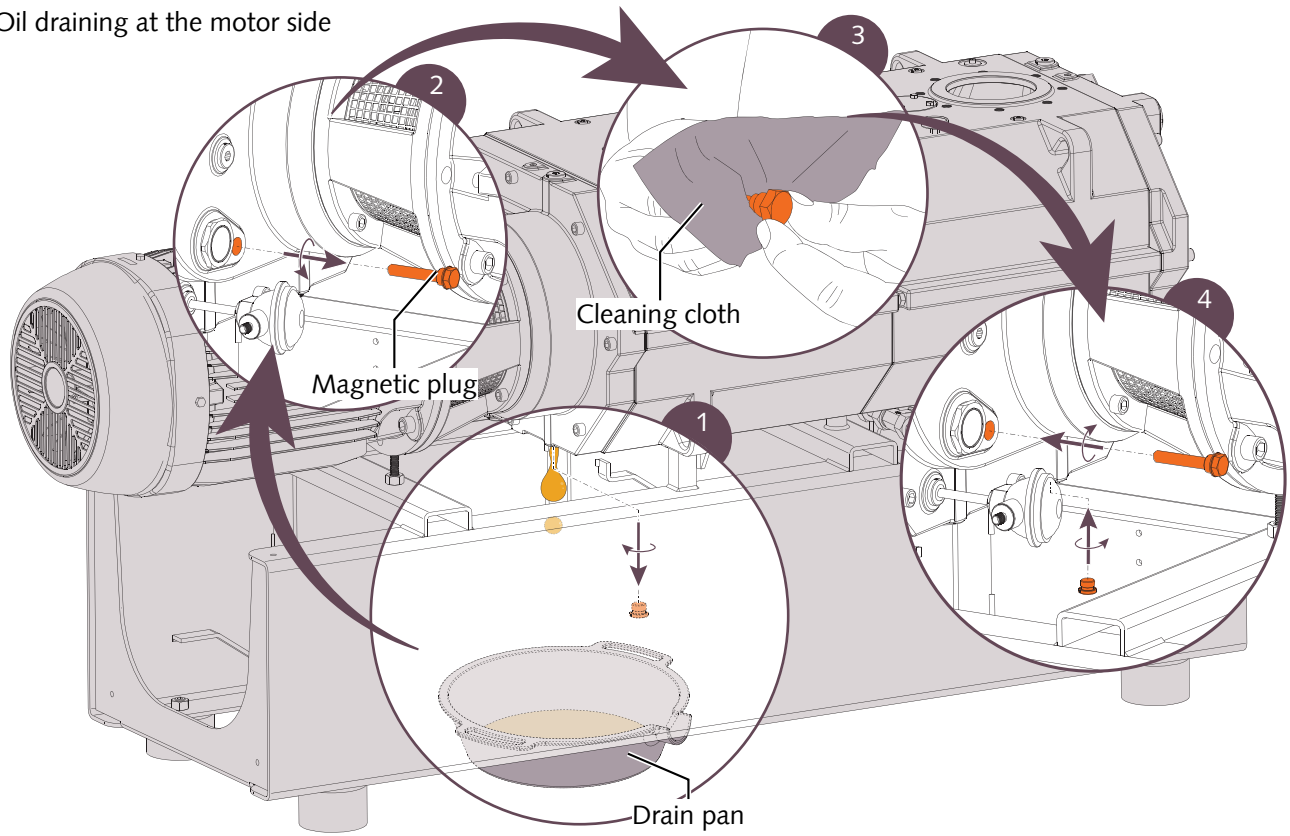

Oil draining at the suction side

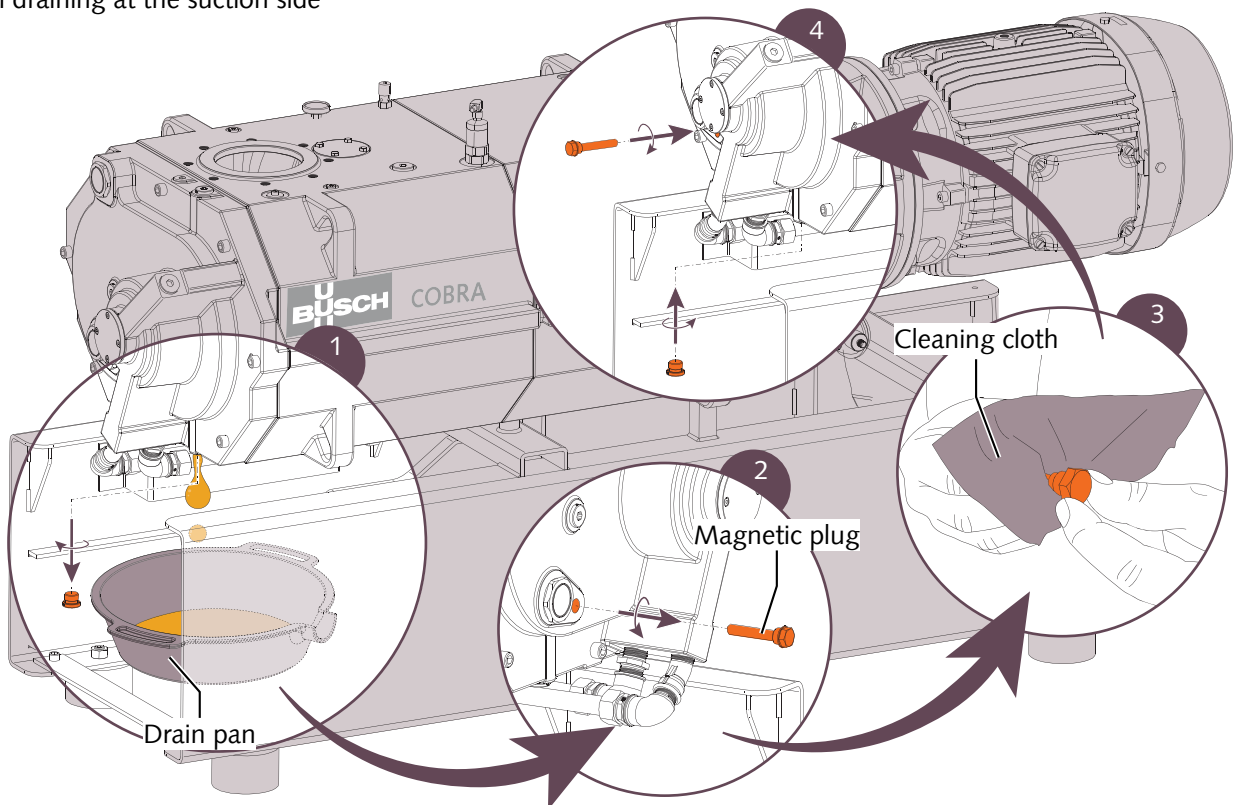

For oil type and oil capacity see Technical Data [▶ 28] and Oil [▶ 28].

Oil filling at the motor side

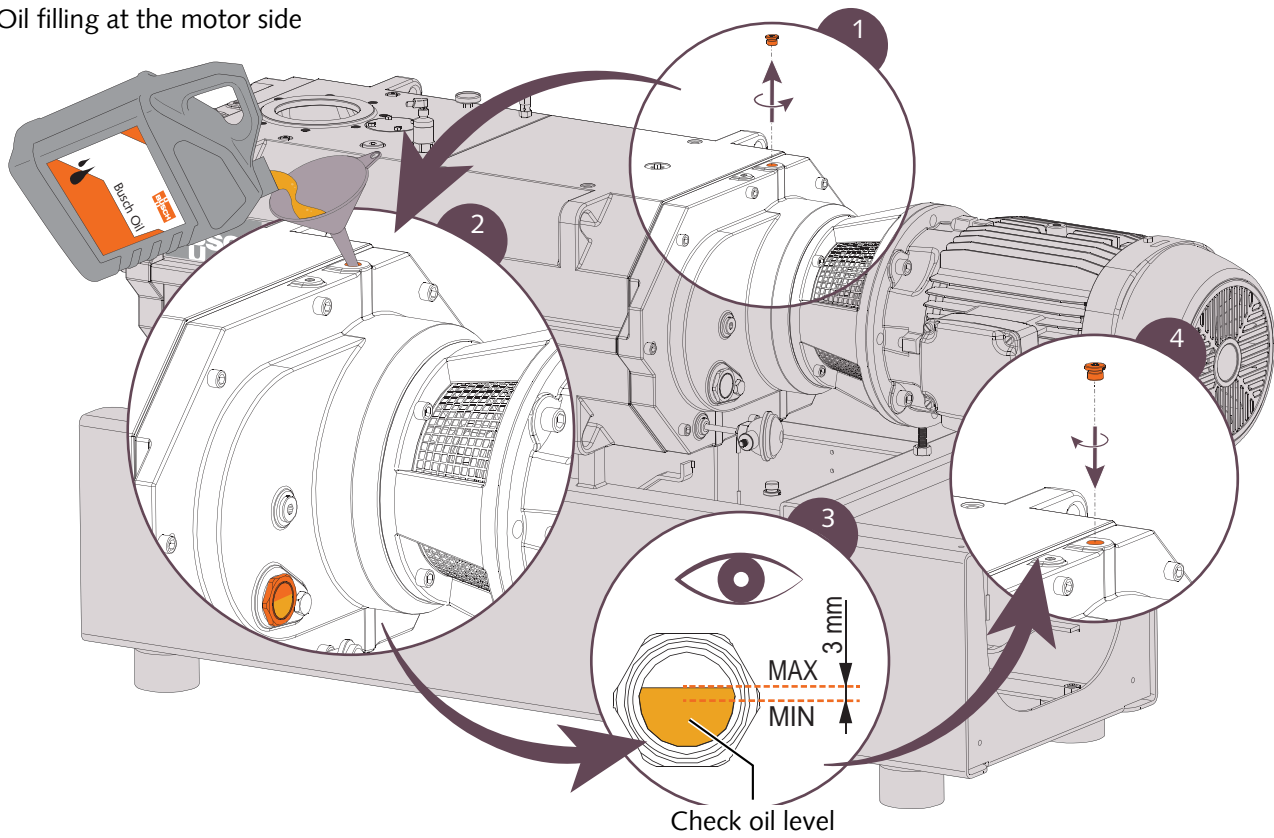

Oil filling at the suction side

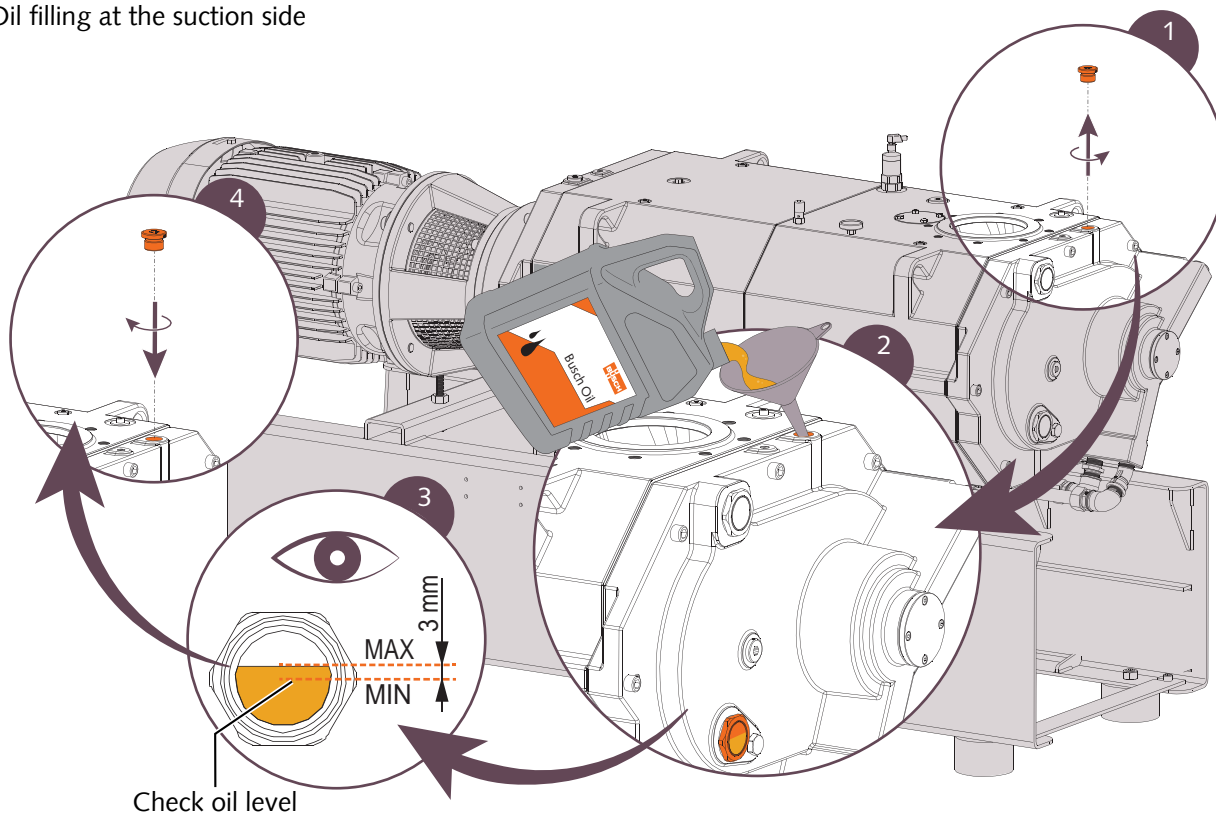

When the oil filling is achieved:

- Write down the oil change date on the sticker.

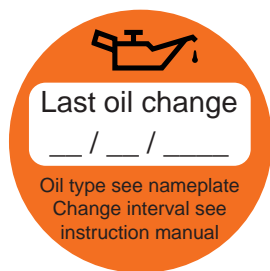

If there is no sticker on the pump:

- Order it from your Busch representative.

7.6 Cooling Liquid Change

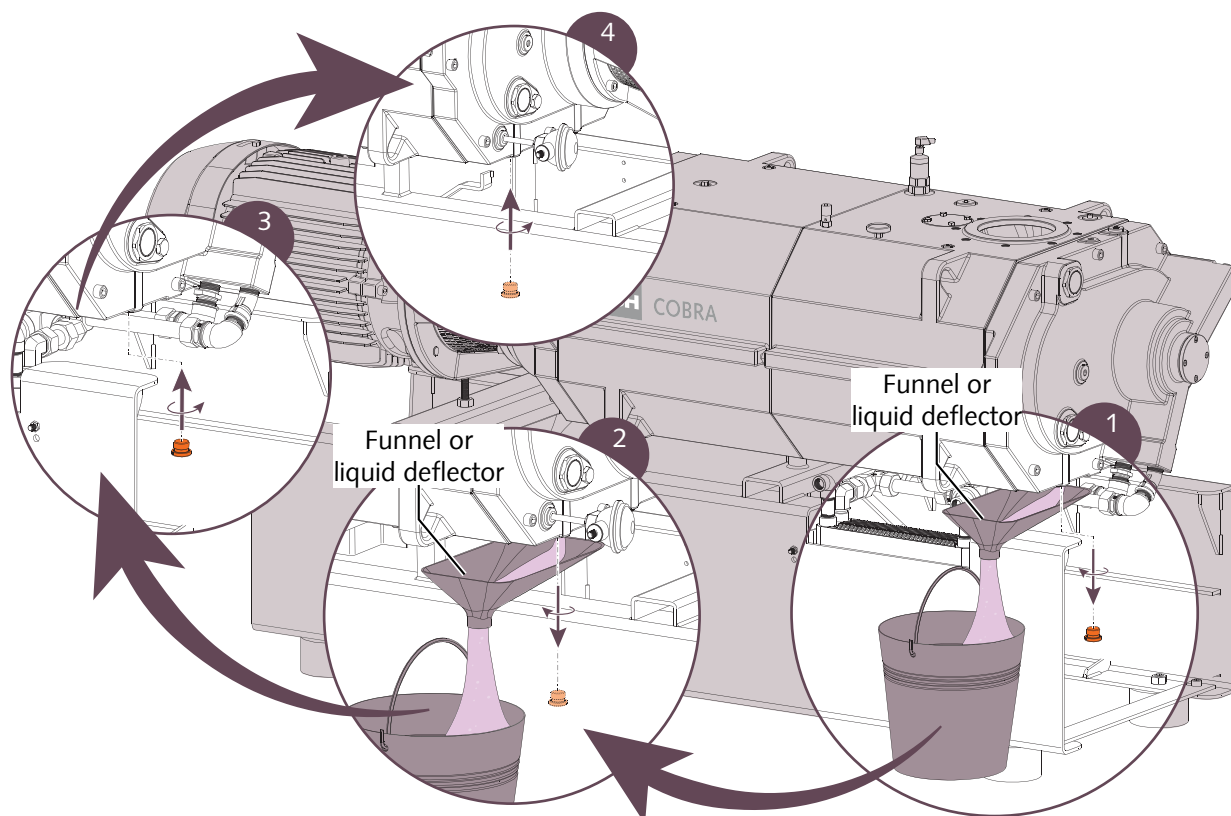

For cooling liquid type and cooling liquid capacity see Technical Data [▶ 28] and Cooling Liquid [▶ 28].

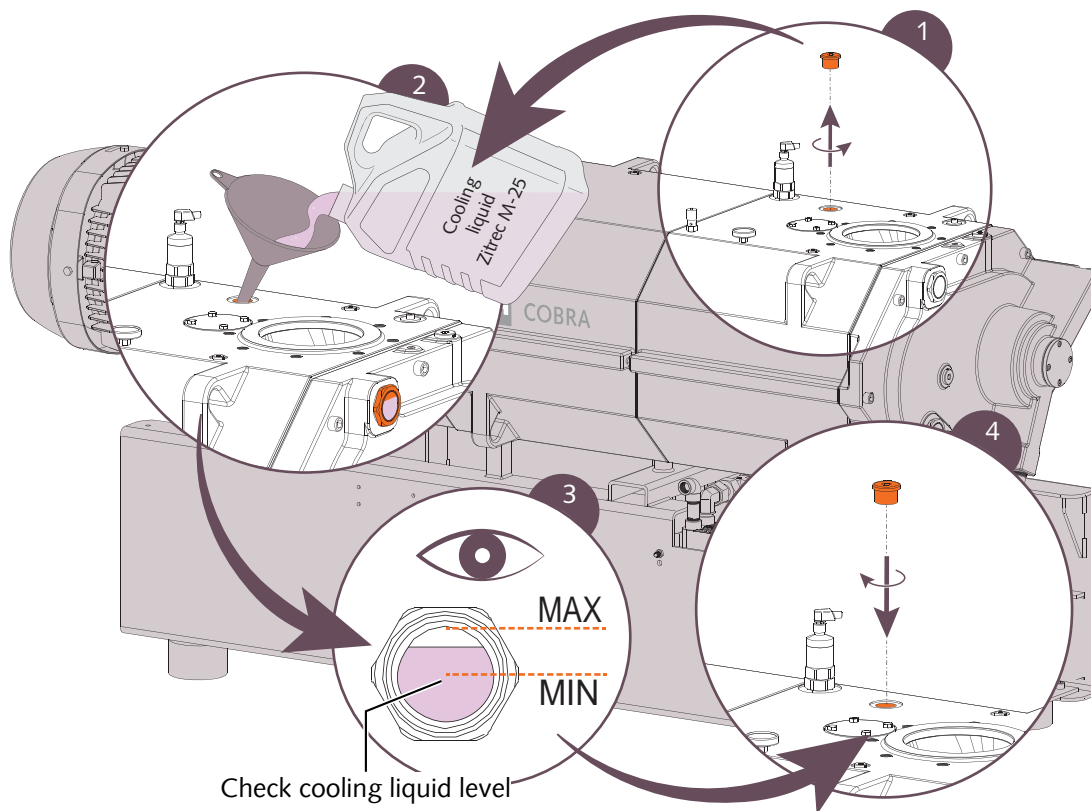

8 Overhaul

! NOTICE

Improper assembly.

Risk of premature failure!

Loss of efficiency!

- It is highly recommended that any dismantling of the machine that goes beyond anything that is described in this manual should be done through Busch.



⚠ WARNING

Machines contaminated with hazardous material.

Risk of poisoning!

Risk of infection!

If the machine is contaminated with hazardous material:

- Wear appropriate personal protective equipment.

In case of the machine having conveyed gas that was contaminated with foreign materials which are dangerous to health:

- Decontaminate the machine as well as possible and state the contamination status in a 'Declaration of Contamination'.

Busch will only accept machines that come with a completely filled in and legally binding signed 'Declaration of Contamination'.

(Form downloadable from www.buschvacuum.com)

9 Decommissioning

- Shut down the machine and lock against inadvertent start up.
- Turn off the water supply.

If the machine is equipped with a barrier gas system:

- Close the barrier gas supply.
- Vent the connected lines to atmospheric pressure.
- Disconnect all connections.

If the machine is going to be stored:

- See Storage [▶ 8].

9.1 Dismantling and Disposal

- Drain the oil.
- Drain the cooling liquid.
- Separate special waste from the machine.
- Dispose of special waste in compliance with applicable regulations.
- Dispose of the machine as scrap metal.

10 Spare Parts

NOTICE

Use of non-Busch genuine spare parts.

Risk of premature failure!

Loss of efficiency!

- The exclusive use of Busch genuine spare parts and consumables is recommended for the proper function of the machine and for granting of warranty.

There is no standard spare parts kits available for this product, if you require Busch genuine parts:

- Contact your Busch representative for the detailed spare parts list.

11 Troubleshooting

Problem	Possible Cause	Remedy
The machine does not start.	The motor is not supplied with the correct voltage.	<ul style="list-style-type: none"> • Check the power supply.
	The rotors are jammed or seized.	<ul style="list-style-type: none"> • Turn the screw rotors manually from the rotor access plug (PMR). • Repair the machine (contact Busch).
	Solid foreign matter has entered the machine.	<ul style="list-style-type: none"> • Remove the solid foreign matter or repair the machine (contact Busch). • Install an inlet filter if necessary.
	The resistance thermometer (TSA) reached the switch point.	<ul style="list-style-type: none"> • Let the machine cool down. • See problem "The machine runs too hot".
	Corrosion in the machine from remaining condensate.	<ul style="list-style-type: none"> • Repair the machine. • Check the process and follow the recommendation in case of Conveying Condensable Vapours [► 17].
	The motor is defective.	<ul style="list-style-type: none"> • Replace the motor.
The machine does not reach the usual pressure on the suction connection.	Suction or discharge lines too long or section diameter too small.	<ul style="list-style-type: none"> • Use larger diameter or shorter lines. • Seek advice from your local Busch representative.
	Process deposits on the pumping components	<ul style="list-style-type: none"> • Flush the machine.
	The machine runs in the wrong direction.	<ul style="list-style-type: none"> • Check the direction of rotation, see Wiring Diagram Three-Phase Motor.
	Internal parts are worn or damaged.	<ul style="list-style-type: none"> • Repair the machine (contact Busch).
The machine runs very noisily.	Wrong oil quantity or unsuitable oil type.	<ul style="list-style-type: none"> • Use one of the recommended oils in the correct quantity, see Oil [► 28].
	Defective gears, bearings or coupling element.	<ul style="list-style-type: none"> • Repair machine (contact Busch).

The machine runs too hot.	Insufficient cooling.	<ul style="list-style-type: none"> • Make sure to comply with the cooling water requirements, see Cooling Water Connection [▶ 10].
	Ambient temperature too high.	<ul style="list-style-type: none"> • Observe the permitted ambient temperature, see Technical Data [▶ 28].
	Temperature of the process gases at the inlet too high.	<ul style="list-style-type: none"> • Observe the permitted gas inlet temperature, see Technical Data [▶ 28].
	The cooling water pump is defective.	<ul style="list-style-type: none"> • Repair the machine.
	Oil level too low.	<ul style="list-style-type: none"> • Top up oil.
The oil is black.	Oil change intervals are too long.	<ul style="list-style-type: none"> • Drain the oil and fill in new oil, see Oil Change [▶ 20].
	The machine runs too hot.	<ul style="list-style-type: none"> • See problem "The machine runs too hot".

For the solution of problems not mentioned in the troubleshooting chart contact your Busch representative.

12 Technical Data

		NC 1000 B
Pumping speed (50Hz / 60Hz)	m ³ /h	840 / 1000
Ultimate pressure (without gas ballast) (50Hz / 60Hz)	hPa (mbar) abs.	≤0.5 / ≤0.1
Ultimate pressure (with gas ballast) (50Hz / 60Hz)	hPa (mbar) abs.	≤0.5 / ≤0.5
Nominal motor rating (50Hz / 60Hz)	kW	22 / 25
Nominal motor speed (50Hz / 60Hz)	min ⁻¹	3000 / 3600
Noise level (EN ISO 2151) (50Hz / 60Hz)	dB(A)	≤75 / ≤81
Ambient temperature range	°C	5 ... 50
Max. allowable counter pressure at the discharge	hPa (mbar)	200
Max. allowable gas inlet temperature	°C	≤50 hPa (mbar) ► 200
		>50 hPa (mbar) ► 70
Relative humidity	at 30 °C	90%
Ambient pressure		Atmospheric pressure
Cooling water requirements		See Cooling Water Connection [► 10]
Oil capacity - motor side	l	1.3
Oil capacity - suction side	l	1.5
Cooling liquid capacity approx.	l	44
Weight approx.	kg	1500

13 Cooling Liquid

		Zitrec M-25 (ready-to-use)
Part number 5 L packaging		0831 563 469
Part number 25 L packaging		0831 563 468

The cooling liquid Zitrec M-25 is ready-to-use and does not require additional water.

For further information, consult the website www.arteco-coolants.com.

14 Oil

		VE 101
ISO-VG		100
Part number 1 L packaging		0831 000 099
Part number 5 L packaging		0831 000 100

15 EU Declaration of Conformity

This Declaration of Conformity and the CE-mark affixed to the nameplate are valid for the machine within the Busch scope of delivery. This Declaration of Conformity is issued under the sole responsibility of the manufacturer. When this machine is integrated into a superordinate machinery the manufacturer of the superordinate machinery (this can be the operating company, too) must conduct the conformity assessment process for the superordinate machine or plant, issue the Declaration of Conformity for it and affix the CE-mark.

The manufacturer

Ateliers Busch S.A.
Zone Industrielle
CH-2906 Chevenez



declare that the machine(s): **COBRA NC 1000 B**

with a serial number from **C1701...** to **C1852...**

has (have) been manufactured in accordance with the European Directives:

- 'Machinery' 2006/42/EC
- 'Electromagnetic Compatibility' 2014/30/EU
- 'RoHS' 2011/65/EU, restriction of the use of certain hazardous substances in electrical and electronic equipment

and following the standards.

Standard	Title of the Standard
EN ISO 12100:2010	Safety of machinery - Basic concepts, general principles of design
EN ISO 13857:2008	Safety of machinery - Safety distances to prevent hazard zones being reached by the upper and lower limbs
EN 1012-1:2010 EN 1012-2:1996 + A1:2009	Compressors and vacuum pumps - Safety requirements - Part 1 and Part 2
EN ISO 2151:2008	Acoustics - Noise test code for compressors and vacuum pumps - Engineering method (grade 2)
EN 60204-1:2006	Safety of machinery - Electrical equipment of machines - Part 1: General requirements
EN 61000-6-2:2005	Electromagnetic compatibility (EMC) - Generic standards. Immunity for industrial environments
EN 61000-6-4:2007 + A1:2011	Electromagnetic compatibility (EMC) - Generic standards. Emission standard for industrial environments
EN ISO 13849-1:2015 ⁽¹⁾	Safety of machinery - Safety-related parts of control systems - Part 1: General principles for design

Person authorised to compile the technical file:

Gerd Rohweder
Busch Dienste GmbH
Schauinslandstr. 1
DE-79689 Maulburg

Chevenez, 16.03.2016

Christian Hoffmann, General director

⁽¹⁾ In case control systems are integrated.

Note

A large, empty rectangular box with a thin gray border, occupying most of the page below the 'Note' header. It is intended for the user to write their notes.

A large, empty rectangular box with a thin gray border, occupying most of the page. It is intended for writing a note.

Busch Vacuum Pumps and Systems

All over the World in Industry

Argentina

www.busch-vacuum.com.ar

Australia

www.busch.com.au

Austria

www.busch.at

Belgium

www.busch.be

Brazil

www.buschdobrasil.com.br

Canada

www.busch.ca

Chile

www.busch.cl

China

www.busch-china.com

Colombia

www.buschvacuum.co

Czech Republic

www.buschvacuum.cz

Denmark

www.busch.dk

Finland

www.busch.fi

France

www.busch.fr

Germany

www.busch.de

Hungary

www.buschvacuum.hu

India

www.buschindia.com

Ireland

www.busch.ie

Israel

www.busch.co.il

Italy

www.busch.it

Japan

www.busch.co.jp

Korea

www.busch.co.kr

Malaysia

www.busch.com.my

Mexico

www.busch.com.mx

Netherlands

www.busch.nl

New Zealand

www.busch.com.au

Norway

www.busch.no

Peru

www.busch.com.pe

Poland

www.busch.com.pl

Portugal

www.busch.pt

Russia

www.busch.ru

Singapore

www.busch.com.sg

South Africa

www.busch.co.za

Spain

www.buschiberica.es

Sweden

www.busch.se

Switzerland

www.busch.ch

Taiwan

www.busch.com.tw

Thailand

www.busch.co.th

Turkey

www.buschvacuum.com

United Arab Emirates

www.busch.ae

United Kingdom

www.busch.co.uk

USA

www.buschusa.com

