



VACUUM CE
TECHNOLOGY

**OPERATING AND MAINTENANCE
INSTRUCTIONS**

(Translation of the original instructions)

OIL-BATH VANE VACUUM PUMPS

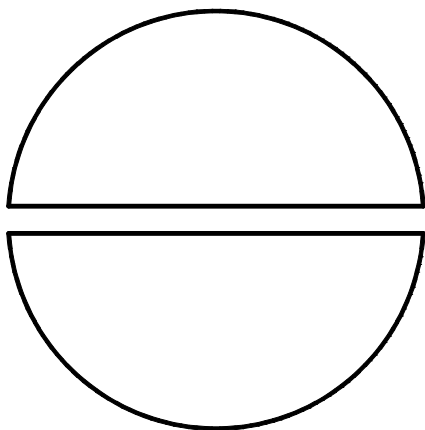

DC.16DEX

INDEX

1	INTRODUCTION	2
1.1	GENERAL INFORMATION	2
1.2	MANUFACTURER INFORMATION	2
1.3	METHOD OF CONSULTATION	2
1.4	PERSONNEL QUALIFICATIONS	2
1.5	PERSONAL PROTECTION EQUIPMENT	3
1.6	INFORMATION PLATE	3
1.7	MARKING	3
2	SAFETY	4
2.1	GENERAL WARNINGS	4
2.2	RESIDUAL RISKS	4
2.3	PICTOGRAMS	5
3	PUMP DESCRIPTION	6
3.1	INTENDED USE AND CONTRAINDICATIONS	6
3.1.1	INTENDED USE	6
3.1.2	CONTRAINDICATIONS	6
3.2	NOISE EMISSION	6
3.3	DIMENSIONS AND CHARACTERISTICS	7
4	INSTALLATION	8
4.1	RECEIPT AND CONTENT VERIFICATION	8
4.2	PACKAGING	8
4.3	TRANSPORT AND HANDLING	8
4.4	STORAGE	8
4.5	ENVIRONMENTAL CONDITIONS	9
4.6	PUMP INSTALLATION	9
4.7	MOTOR INSTALLATION	10
4.8	USER SYSTEM	10
4.9	CONNECTION	10
4.9.1	INTAKE AND OUTLET CONNECTIONS	10
4.9.2	WIRING	11
5	OPERATING INSTRUCTIONS	12
5.1	OPERATION	12
5.1.1	FILLING THE OIL TANK	12
5.1.2	START-UP	12
5.1.3	OIL CLEANING	13
5.1.4	STOP	13
6	MAINTENANCE	14
6.1	GENERAL WARNINGS	14
6.2	MAINTENANCE TABLE	14
6.2.1	CHECK OIL LEVEL	14
6.2.2	CHANGE OIL	15
6.2.3	CHECK AND CLEAN GAS BALLAST	15
6.2.4	CLEAN MOTOR FAN GUARD AND CLEAN THE PUMP	15
6.2.5	CHANGE VANES	15
6.3	SPARE PARTS	16
7	HOW TO RETURN THE PUMP	17
8	DISMANTLING	18
9	TROUBLESHOOTING	19

1 INTRODUCTION

1.1 GENERAL INFORMATION

This manual is meant to provide you with important information for the safety of persons involved in pump use and maintenance.

This manual, originally written in ITALIAN, is an integral part of the pump and must be preserved with care for the life of the pump itself. In the event of sale, lease or loaned use of the pump, it must be delivered to the new user along with EC declaration of conformity.

Carrying out any operations on the pump before reading and fully understanding all instructions in this manual is prohibited.

The images contained in this document are examples only and are not binding for the Manufacturer. The Manufacturer reserves the right to make changes to components, product improvement parts and any other without updating this manual, if said components or parts do not alter pump operation and safety.

1.2 MANUFACTURER INFORMATION

D.V.P. Vacuum Technology s.p.a.

Via Rubizzano, 627
40018 - S. Pietro in Casale (BO) - ITALY

Ph +3905118897101
Fx +3905118897170
e-mail: info@dvp.it
web site: <http://www.dvp.it>

Please always include the following information in all communications regarding the pump:

- pump model and serial number
- year of manufacture
- date of purchase
- detail information regarding problems verified

1.3 METHOD OF CONSULTATION

For improved understanding of the information provided in this manual, warnings or instructions considered critical or hazardous are marked with the following symbols:



HAZARD

Failure to comply with these instructions may cause hazards to persons and cause sources of ignition of potentially explosive atmospheres (ATEX).



WARNING

Failure to comply with these instructions may cause damage to the pump.

1.4 PERSONNEL QUALIFICATIONS

To ensure that all operations performed on the pump are carried out safely, operators must have the qualifications and requirements to carry out its operations.

Operators are classified as follows:



FIRST LEVEL OPERATOR:

Unqualified personnel, having no specific skills, able to perform simple tasks only.



MECHANICAL MAINTENANCE OPERATOR:

Technician qualified to work on mechanical parts to carry out any necessary adjustments, maintenance or repairs. Not qualified to work on electrical systems in the presence of voltage.



ELECTRICAL MAINTENANCE OPERATOR:

Technician in charge of all operations of an electrical nature. Can operate in the presence of voltage inside cabinets and connector boxes.



HAZARD

The qualified technician must have the necessary expertise in the field of on site systems in ATEX classified areas.

1.5 PERSONAL PROTECTION EQUIPMENT

This manual assumes that the pump has been installed in workplaces, which comply with all mandatory safety requirements; in particular, it is mandatory that personnel are equipped with personal protective equipment in relation to the activities that must be performed.

1.6 INFORMATION PLATE

All pumps are equipped with an identification plate that contains the manufacturer's name, address, CE marking, ATEX marking and technical data of the pump itself.

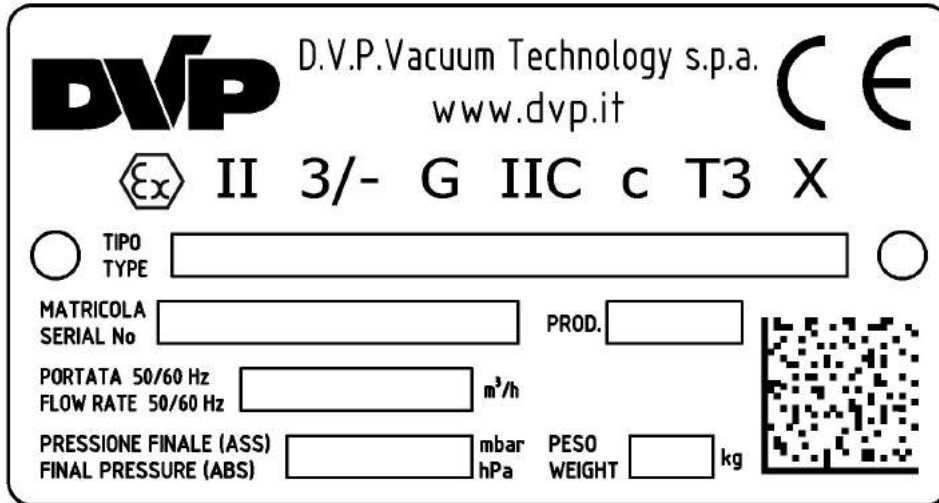

WARNING

Removing or tampering with the identification plate is strictly prohibited.

1.7 MARKING

This pump has been certified with the following marking:

CE **Ex** **II 3/- G IIC c T4 X**

Where:



CE label indicating compliance with Directive 94/9/EC (ATEX)



Construction label suitable for use in potentially explosive atmospheres ATEX

II

Equipment unit; **I**=underground **II**=surface

Category of the equipment; pump in category 3 **internal**, NOT ATEX certified for the external surface.

3/-

"Category 3 comprises equipment designed to operate in accordance with operating parameters established by the manufacturer and ensuring a normal level of protection. The equipment in this category is intended for environments where it is unlikely that explosive atmospheres are produced that are caused by gases, vapours, mists or mixtures of air and dust, and if occurring only for a short time. The equipment in this category guarantees the required level of protection during normal operation."

G

Type of explosive atmosphere; **G**= Gas, Vapours, Mists **D**=Dust

IIC

Class of Gas; the gas can be group IIA, IIB or IIC

c

Type of protection used; **C**=Constructional safety

T4

Temperature class; **T4**:Maximum temperature of exposed surfaces = 135°C

X

Additional marking; Working Ambient Temperature required +12°C ÷ +40°C



HAZARD

Read carefully the meaning of the marking of the pump since this determines important conditions of use in potentially explosive atmospheres (ATEX).

2 SAFETY

2.1 GENERAL WARNINGS

L'atmosfera esplosiva costituisce un grave pericolo per la salute dei lavoratori e pertanto devono essere attivate tutte le misure di prevenzione possibili, in accordo con le normative locali vigenti.

Gli impianti elettrici installati in zona classificata ATEX sono soggetti a denuncia all'INAIL e verifica periodica biennale da parte dell'ASL/ARPAV.

It is important to read this manual before performing any operation on the pump. Compliance with the safety standards of the country in which the pump is installed and requirements of qualified personnel for various maintenance, use, installation, etc. are recommended throughout the life of the pump.

The main rules of conduct to be observed for operation at a suitable level of security are the following:

- Installation, operation, maintenance, etc. operations should always be performed by qualified, trained personnel.
- Without exception, always wear necessary personal protective equipment.
- Always perform all cleaning, adjustment and maintenance operations with all power equipment cut off.
- Do not direct water jets toward electrical parts, even if they are protected by enclosures.
- Do not smoke during work or maintenance, especially where solvents or flammable materials are being used.
- Do not damage symbol plaques or pictograms on the pump. If they should accidentally become damaged, immediately replace them with other identification plaques.

D.V.P. Vacuum Technology s.p.a. disclaims any liability for damage to persons or property resulting from improper use of the pump, from tampering with its safety apparatus or failure to observe operational safety standards.

2.2 RESIDUAL RISKS



HAZARD

This pump has been designed to minimise residual risks to personnel. We urge you, however, to take the utmost care and attention in carrying out maintenance operations. The confidence gained with frequent contact with the pump too often leads users to forget or underestimate risks.

High temperature hazard

Pump surfaces can exceed a temperature of 70°C. Install the pump in a protected area that is accessible only by authorised personnel and only perform operations when the pump is stopped and cooled.

Hazard generated by low pressure

Avoid contact with pump intake attachment during operation. Before any interventions, isolate the pump from the system, introduce air into the intake circuit and clean the area with an ATEX atmosphere. Contact with low pressure points can cause accidents.

Hazard generated by pressure

The pump tank is pressurised. Do not open and do not leave oil filler or drain plugs open during operation.

Danger of emission of an ATEX atmosphere

The pump will draw fluids, gases or vapours containing potentially explosive atmospheres (ATEX) The intake/discharge connections and the filling/draining oil caps must be securely tightened and properly connected to the system in order to avoid contamination of the working environment with an ATEX atmosphere.

Danger from the emission of harmful and/or explosive substances

The pump exhaust air contains traces of oil mist and an ATEX atmosphere; check the compatibility of the oil with the system operator and that the discharge of the pump is securely connected to prevent the escape of an ATEX atmosphere into the working environment.

Faults or wearing of seals may cause oil lubricant leaks and an explosive atmosphere. Avoid dispersion in soil, the pollution of other materials and the emission of an ATEX atmosphere.

Whenever air containing hazardous substances are sucked in (i.e. biological or microbiological agents), use abatement systems placed before the vacuum pump. Used oil must be disposed of according to applicable regulations in the country of pump use.

Electrical hazard

Electrical equipment in the pump includes live parts which, upon contact, can cause serious damage to persons and property. Any kind of intervention on the electrical system must be performed by qualified personnel.

Fire and/or explosion hazard

Use of the pump in areas that are inconsistent with its marking, for any uses not provided for or prohibited by this manual as well as a lack of proper maintenance can cause malfunction with a risk of overheating, fire or explosions. In case of fire, do not use water to extinguish the flames, but use dry chemical or CO₂ or other means compatible with the presence of electrical equipment and lubricants.

Slip and fall hazards

The "L" series vacuum pumps use lubricant to operate. A simple maintenance or improper use not complying with the instructions included in this manual can damage the gaskets and/or seals and cause the lubricant to spill on the floor constituting slip and/or fall hazards for personnel.

Entanglement hazard

There is a permanent impending hazard of entangling or entrapping hair and clothing in the cooler fan inside the guard near the fan casing on the electric motor. Tie long hair up and do not wear baggy clothing, long laces or other items that could get caught up.

Part projection hazard

Install the pump in order to avoid those in charge of works being directly hit by parts or bits of parts flying through the fan cover casing due to the cooling fan breaking.

2.3 PICTOGRAMS

Pictographs with the warning symbols and safety symbols for operators have been applied to the pump. Read carefully and take note of the symbols and their messages before using the pump.

**ELECTRICAL HAZARD**

The pump is near electrical connections (protected) but where accidental contact can cause electric shock and death.

**HOT SURFACE HAZARD**

The pump is close to surfaces with temperatures exceeding 70°C which may lead to burns of medium severity.

**EARTH**

Electrical connection point to earth the pump.

D.V.P. Vacuum Technology s.p.a. disclaims any liability for damage to persons or property due to non-compliance with instructions indicated in pictograms or their improper preservation.

3 PUMP DESCRIPTION

3.1 INTENDED USE AND CONTRAINDICATIONS

3.1.1 INTENDED USE

The pumps described in this manual are of the rotary vane oil bath type. These pumps are specifically designed for ATEX Zone 2 suction from clean air, flammable gas from **IIA, IIB** and **IIC** units or small amounts of water vapours and must be installed in **NON ATEX** classified environments; their marking and certification and for internal ATEX (see 1.7 "Marking" of this manual).

The temperature of the fluid, gas or vapour produced by the pump and that from the environment in which it is installed must be between **+12°C** and **+40°C**.



HAZARD

The user must pay particular attention to the Marking of the pump.

Any other use is prohibited. The Manufacturer is not liable for any damage to persons and/or property caused by improper use or not allowed use of the pump.

This pump is suitable for emptying closed containers with a capacity that the pump can reach the final pressure in less than 20 minutes.

3.1.2 CONTRAINDICATIONS



The pump cannot work with the intake completely open for more than 10 minutes.



Any use other than that for which the pump was constructed is to be considered an abnormal condition and therefore can cause damage to the pump and pose a serious danger to the operator.

Below is a series of operations involving improper use of the pump, which are not permitted under any circumstances.

- Do not install and/or use the pump in an ATEX classified environment; The pump is certified and marked for **internal ATEX** (see 1.7 "Marking" of this manual). The use of the pump in an environment where the presence of ATEX atmospheres has been detected can cause explosions or fires;
- Do not use non-original spare parts or parts not provided by the manufacturer.
- Do not use the unit to pump solid materials, chemicals, powders, solvents or other substances differing from those permitted. These types of materials may damage the unit, degrade its performance or reduce its life.
- do not expose the pump to rain, steam or excessive humidity.
- Do not place or store near in the proximity of flammable or combustible materials or substances.
- Do not use the pump as a compressor.

3.2 NOISE EMISSION

This pump has been designed and constructed to reduce noise at its source.

The sound pressure levels contained in the table of technical specifications were measured at maximum vacuum and outlet conveyed according to UNI EN 2151.

3.3 DIMENSIONS AND CHARACTERISTICS

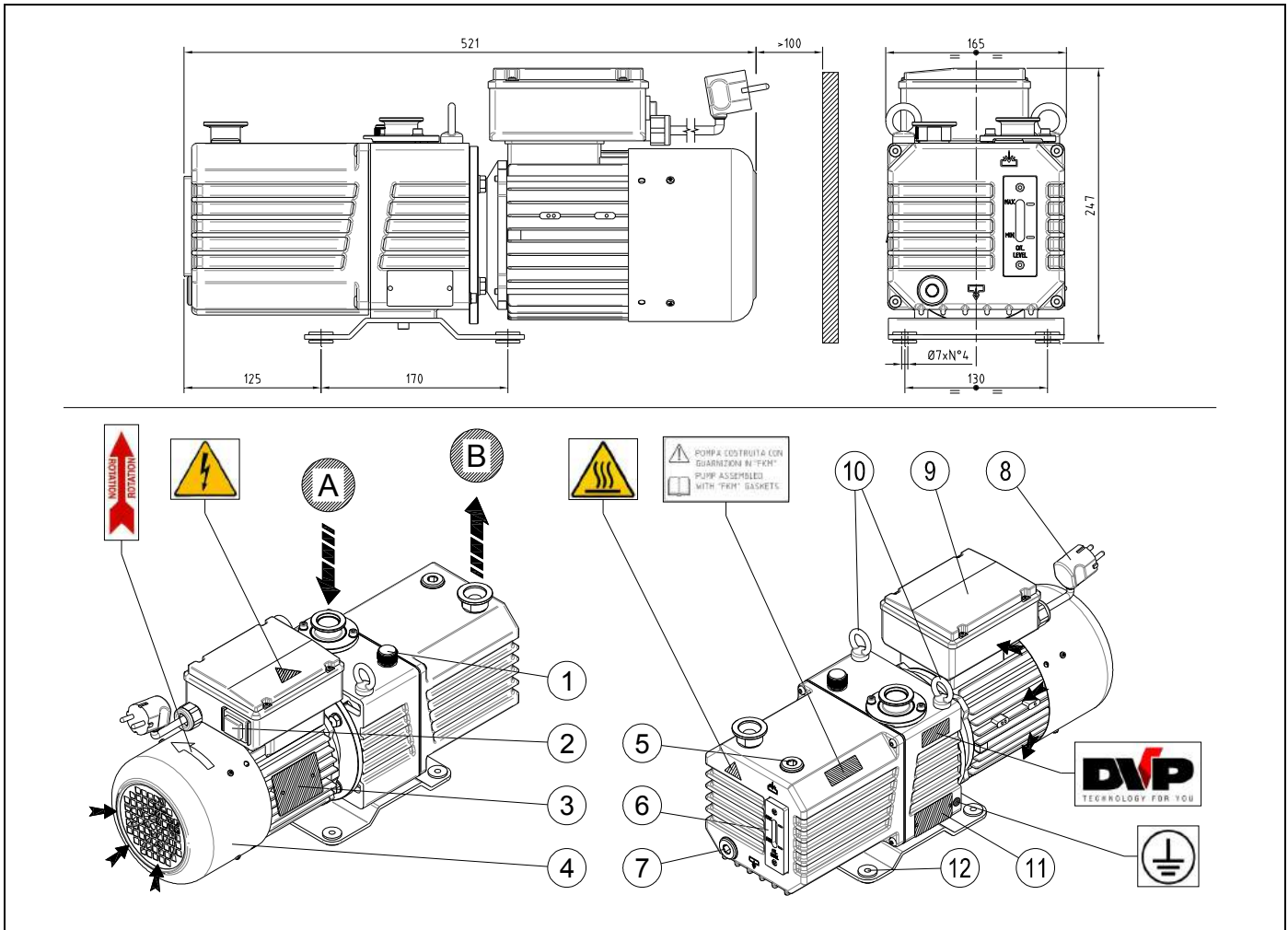

A	Intake
B	Air outlet
1	Gas ballast
2	Start / Stop switch (only 1~)
3	Motor rating plate

4	Motor fan guard
5	Oil filler plug
6	Oil sight glass
7	Oil drain plug
8	Power cable (only 1~)

9	Terminal board
10	Lifting eyebolts
11	Information plate
12	Attachment point

TECHNICAL SPECIFICATIONS

		DC.16DEX	
		50 Hz	60 Hz
Number of stages		2	
Nominal pumping speed	m ³ /h	17,0	21,0
Pneurop pumping speed	m ³ /h	16,0	17,0
Total final pressure (Abs.)	mbar - hPa	0,005	
Partial final pressure (Abs.) (McLeod)	mbar [micron]	0,0005 [0,37]	
Final pressure with gas ballast (Abs.)	mbar - hPa	0,08	
Max inlet pressure for water vapour	mbar - hPa	17	23
Max water vapour pumping rate	Kg/h	0,22	0,35
Motor power	kW (1~/3~)	0,75 / 0,55	0,90 / 0,66
Nominal r.p.m.	n/min	1400	1700
Noise level (UNI EN ISO 2151) (K 3dB)	dB(A)	52	54
Weight	kg (1~/3~)	25,5 / 22,5	
Type of oil	cod. DVP	SW100	
Oil quantity	Min+Max dm ³	0,62 ÷ 0,80	
Pump Intake / Outlet		DN25 / 1/2" G	
Operating temperature *	°C	+60 ÷ +65	
Required room temp. for place of installation	°C	+12 ÷ +40	
Temperature of the fluid, gas or vapour processed	°C	+12 ÷ +40	
Ambient temperature for storage/transport	°C	-20 ÷ +50	
MAX humidity / altitude		80% / 1000m a.s.l. **	

(*) Room temperature 20°C.

(**) Please contact the Manufacturer if environmental conditions are different from those prescribed.

4 INSTALLATION

4.1 RECEIPT AND CONTENT VERIFICATION

Upon receipt of the pump, verify that the packaging is intact. If everything is intact, unpack the contents and check the pump. If packaging shows signs of damage due to transport or storage conditions, immediately notify the shipping agent and the manufacturer.

It is always necessary to check that the material received corresponds to its accompanying document.

Packages should be opened taking all precautions to avoid harm to people and the contents thereof.

4.2 PACKAGING

Depending on the size and based on the mode of transport, the pump is packaged in the following ways:

- single box with infill material;
- on wooden pallets with cardboard covers;
- in single boxes positioned on pallets with protective film.

The pallet wood can be reused or recycled in accordance with applicable laws in the country of pump installation. Other materials such as cardboard, plastic or protective film must be disposed of in accordance with local regulations.

Do not burn or disperse package components in the environment.

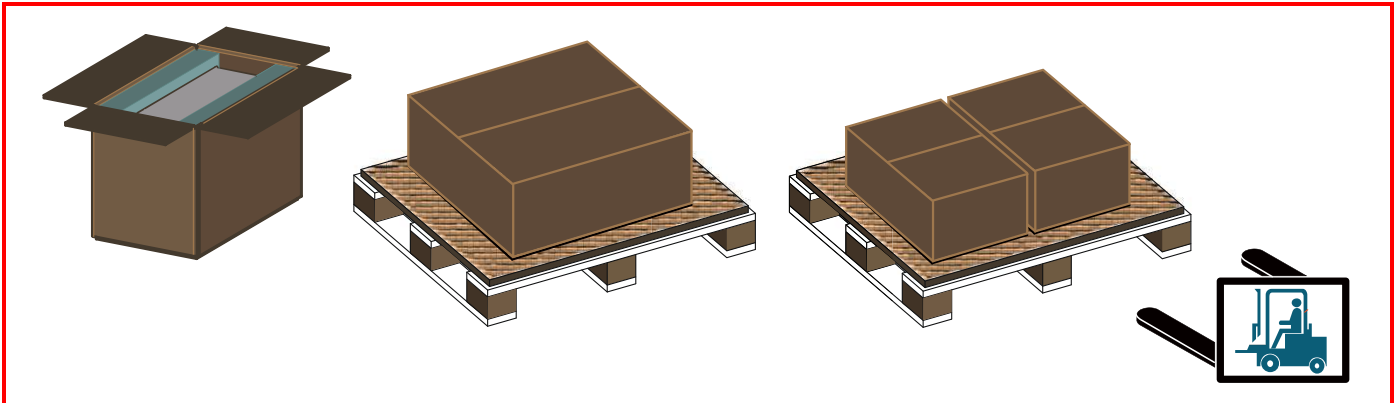

4.3 TRANSPORT AND HANDLING



HAZARD

All transportation, lifting and handling operation must be performed by qualified and experienced personnel.

The pump can be raised and moved only with forklift trucks or with lifting equipment (ropes, hooks, etc.) applied to the pump as shown in the figure and adjusted to the weight of the pump itself, reported in 3.3 "Dimensions and Characteristics" of this manual and on the identification plate. It is expressly forbidden the manual handling and transport of the pump.

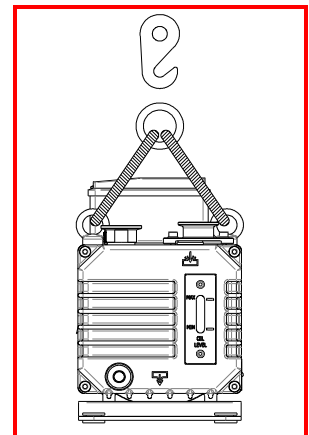

WARNING

Prepare the pump as detailed in the next chapter and empty the oil tank (see 6.2.2 "Changing the oil" of this manual) for transport.

4.4 STORAGE

Drain the pump of oil inside and close the intake and outlet with the appropriate protections. The pumps are to be stored in their packaging and stored in covered, dry, protected places that are not exposed to bright sunlight, with temperatures in the range indicated in the table of technical specifications.

In case of long periods of stop inside the warehouse or out of production with storage, the location should meet the specifications described in Chapter 3 (Pump description). In order to keep rubber parts and lip seals efficient and properly working, we recommend to operate the pump for at least 30 minutes every 6 months with the intake closed, following the instructions and provisions described in this manual, paying particular attention to those in Chapter 5 (Use instructions). The non-observance of the provisions could cause the rubber parts to degrade leading to oil leakages during operation.

4.5 ENVIRONMENTAL CONDITIONS

Legislative decree 81/08 gives the user the task of classifying the AREAS and then to check under their own responsibility, that the area where the pump will be installed is consistent with its CATEGORY.

The pump is designed to extract and process fluids, gases or vapours containing ATEX atmospheres from an area classified as having danger of explosion **AREA 2** according to Directive 99/92/CE (Title XI Legis. 81/08) and be installed in environments that are **NOT** classified **ATEX** (see 1.7 "Marking" and 3.1.1 "Intended Use" of this manual).

AREA 2: *"Place where it is unlikely that an explosive atmosphere consisting of a mixture of air and flammable substances in the form of gas, vapour or mist, is present during normal operation but, if it occurs, will persist for only a short period".*

D.V.P. Vacuum Technology s.p.a. disclaims any liability for the improper installation of the pump in areas other than those certified.



HAZARD

Any use of the pump to process fluids, gases or vapours containing potentially explosive atmospheres (ATEX) in areas other than that certified (i.e. zone 1 or 0) is a serious danger to the health and safety of people.

Any use of the pump to process fluids, gases or vapours in "normal atmospheres" (NON-explosive) does not affect its operation or the safety of people.

The pump must be installed and used in a covered and adequately lit location. The installation area must meet all requirements of height, air circulation and meet the requirements imposed by existing legislation.

Temperature, Humidity and altitude

The corresponding limit values are shown in the table of the technical specifications (see 3.3 "Dimensions and characteristics" of this manual). Please contact the Manufacturer if environmental conditions are different from those prescribed.

Lighting

All areas must be illuminated evenly and sufficiently to ensure all operations included in this manual and must be without shadows, reflections, glare or eyestrain.

4.6 PUMP INSTALLATION



HAZARD

Before carrying out any interventions, make sure that the area has been cleared of the possible presence of potentially explosive atmospheres (ATEX).

To ensure perfect pump operation, house and place it according to the following conditions:

- Allow sufficient space on the perimeter sides of the pump and make sure to keep the motor ventilation side free.
- Make sure the free space adjacent to the pump allows easy access to components for inspection or maintenance and also allows access for suitable lifting equipment.
- The pump is equipped with mounting points. It is necessary to ensure it locks onto a perfectly horizontal plane in order to avoid tilting in case of transportation by the system user.
- Some models are already equipped with rubber vibration dampers installed at pump attachment points. Whenever the model has not been equipped, ensure installation of such equipment so as not to transmit vibration to the pump.
- Ensure there is ventilation in the room, or inside the machine housing the pump and prevent air coming in from the cooling fans, which could cause discomfort to personnel.
- Make sure there is no loss of fluid, gas or vapours from the intake and exhaust pipes or fittings of the pump.



HAZARD

Do not install the pump in any area with dust or other materials that could clog or rapidly cover cooling surfaces.

4.7 MOTOR INSTALLATION

It is possible to install any type of electric or hydraulic motor that has the features described in the table of technical data, with flange and shaft corresponding to:

M80/4 - B5 size with flange and shaft with a reduced size of M71 as per standard IEC-72.



WARNING

This pump need motor monophasic with high starting torque motor with mechanical disengager.



WARNING

Install the coupling on the motor by following the following instructions:

- Fit the coupling on the motor shaft until the proper position is reached.
- Tighten screw "A" to firmly fix the coupling to the shaft.

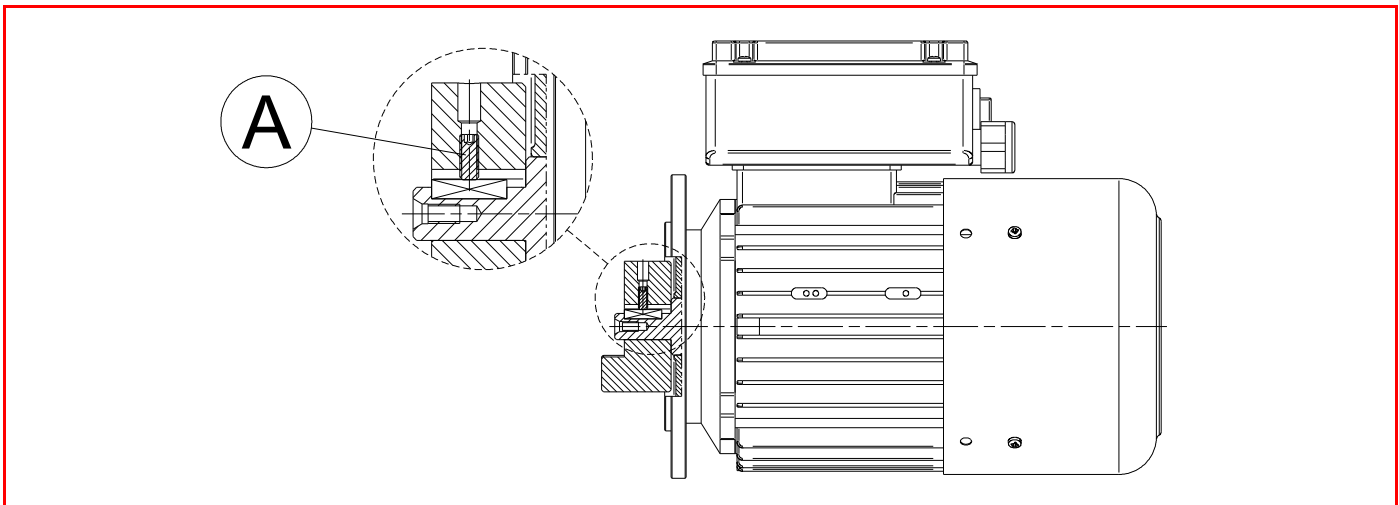

4.8 USER SYSTEM

HAZARD



The user must ensure that the fluid, gas or vapour processed by the pump does not produce unusual chemical reactions (e.g. exothermic chemical reactions) that can lead to the maximum permitted surface temperature being exceeded or a degradation in the level of protection of the pump itself.

HAZARD



The user must ensure that the temperature of the flammable liquid, gas or vapour produced by the pump is higher than the temperature of the same class ($T_4 = 135^{\circ}\text{C}$), shown on the identification plate.

Make sure that no harmful substances contaminate the user system during installation.

If you wish the system to maintain vacuum even when pump is stopped, install a cutoff valve between pump and system.

Make sure that no vibrations or stresses are transmitted to the pump connection.

4.9 CONNECTION



HAZARD

Pump connections should be performed by skilled and trained personnel only.

4.9.1 INTAKE AND OUTLET CONNECTIONS

User system connections (both intake and outlet) must be performed with pipes with a diameter equal to or greater than the pump suction inlet. The weight of pipes or any expansions must not burden the pump.

It is advisable to make the final connection to the pump using flexible pipe or fittings. It is important to tighten all pipes and couplings. Very long pipes or pipes with a diameter that is too small diminish pump performance.

**HAZARD**

Check the connection of the intake and discharge system of the pump to ensure that fluids, gases or vapours processed do not contaminate the working environment and atmosphere surrounding the pump.

**WARNING**

Always install an intake filter, especially if the pump is to work with air that might contain foreign matters.

Pump outlet gases must be treated in such a way that they do not contaminate the working environment and the surrounding atmosphere. If condensable vapours are pumped in, the discharge hose should be routed downwards and have no bends to prevent the condensate produced in the discharge line from building up or flowing back into the pump.

Never use friction hoses with hose diameters smaller than the intake diameter. Avoid exceeding hose lengths, tight bends or bends spaced too closely together.

**HAZARD**

Do not insert outlet fitting pipes or devices that block or impede the disposal of outlet gases (max overpressure exhaust 0.3 bar).

4.9.2 WIRING**WARNING**

Check that network voltage and frequency correspond to values contained on the motor rating plate.

The connection cable must be adequate for the power absorbed by the pump (absorption values are shown on the pump motor rating plate) taking into account the environmental conditions of operation.

**HAZARD**

Always perform earthing of the electric motor and the pump (see 3.3, "Dimensions and Characteristics" of this manual).

Always install a security system between the pump and the electric power supply. Pump absorption values are shown on the motor rating plate.

1~ Version (standard): The pump comes complete with power cable and start/stop switch. The operator should install a plug and connect to an electrical panel provided with electric protection.

3~ and OEM Version: Pump wiring must be connected inside the motor terminal board. See the wiring diagram inside the terminal board or on motor rating plate. Install an electric protection system.

**WARNING**

Check that the direction of rotation is correct before starting the pump for the first time or after changing the electrical connections.

The correct direction of rotation is indicated by the arrow on the pump (see 3.3 "Dimensions and characteristics" of this manual). Pump operation with a rotation direction that is opposite to that indicated can severely damage the pump itself.

5 OPERATING INSTRUCTIONS

5.1 OPERATION

Checks to be performed before start-up:

- The pump is supplied without any oil in it. Use the supplied oil or, alternatively, an alternative lubricant of another brand but with similar characteristics;
- Make sure the intake and discharge of the pump are properly connected to the system and that, especially the exhaust, is not obstructed by fittings or valves.

HAZARD



Use a lubricating oil that has a flash point above 135°C (T4), in order to avoid that this could create an explosive atmosphere (ATEX).

Lube-free operation causes serious damage to the pump and the potential degradation of the level of protection of the pump from the danger of explosion.



WARNING

A higher quantity of oil than necessary may cause clogging of the oil separators (if installed) and damage to the pump or the electric motor.

5.1.1 FILLING THE OIL TANK



HAZARD



Before carrying out the operations listed below, isolate the pump from the operating system by means of an isolation valve (required in 4.8 "System User" of this manual) and from the power supply, then clean the surrounding area from the possible presence of a potentially explosive atmosphere (ATEX) due to the opening of the oil filler cap.



WARNING

When filling the oil tank never exceed allowed maximum level.

- Undo the oil filler plug;
- Pour oil in the tank up to mid-range of the oil sight glass;
- Close the filler plug;
- Remove all oil spills from the pump and/or floor.

5.1.2 START-UP



HAZARD

The pump may reach high temperatures when operating.

1~ Version: Operate the switch on the terminal board.

3~ and OEM Version: Operate the start control on the user system.

After start-up, the pump may run slower than the regular rpm if room temperature is lower than allowed as seen on the technical data table. It may also run lower if the oil is contaminated or the supply voltage is lower than the required voltage as indicated on the motor rating plate.

If nominal rpm is not reached within a few seconds, the thermal switch fitted to protect the pump must trip (installation required in 4.9.2 "Wiring" of this manual).

WARNING



If water vapour should be taken in, take the pump to a steady temperature by leaving it to run for approximately 30 minutes with the suction inlet closed and the system containing the water vapour isolated before starting the work cycle.



WARNING

Make sure the pump is working at the allowed pressure value and do not leave the pump running for a long time (>10min) with the suction inlet completely open.



WARNING

It is advisable not to start the pump more than 12 times per hour to avoid excessive energy consumption and damage to the pump.

**HAZARD**

Full r.p.m. pump operation must be without vibration or unusual noise. If these are present, stop the pump immediately, search for the cause and eliminate it.

5.1.3 OIL CLEANING

When oil looks dark or cloudy or when oil level rises, this means that oil contains foreign matters. For the pumps equipped with gas ballast must follow this procedure:

- Close the system cutoff valve. The pump must operate with the intake completely closed;
- Unscrew the ballast valve no.5 of 2 turns;
- Let pump run under these conditions for at least 1 hour;
- If oil appearance is not back to normal (light colour and no signs of emulsifying), change oil.

5.1.4 STOP

The pump must be stopped by cutting off the power supply.

If the pump is to be powered off, decontaminate the oil and let it run with closed intake for about 30 minutes.

This procedure prevents the pump from being damaged during following start ups, allows to eliminate any moisture inside the intake chamber and to avoid the oxidation of the rotor.

In the case of long machine downtime, completely drain the oil from the pump to avoid hazards of frost during cold weather or corrosion due to possible chemical alteration of the stagnant liquid in the pump.

6 MAINTENANCE

6.1 GENERAL WARNINGS

For good maintenance:

- Immediately verify the causes of any malfunctions (excessive noise, overheating, etc.);
- Pay particular attention to safety devices;
- Make use of all documentation provided by the manufacturer (instruction manuals, wiring diagrams, etc.);
- Use only appropriate tools and original spare parts.

In the event of a failure to understand the information or procedures contained in this chapter, contact D.V.P. Vacuum Technology s.p.a. for clarification before proceeding.



Only trained or authorised personnel have the necessary expertise to perform tasks with the technique appropriate for intervention. In particular, the personnel must have the necessary expertise relating to ATEX classified systems.



HAZARD

Do not perform any type of operation, modification and/or repair of any kind, except for those listed in this manual.



HAZARD

All maintenance operations must be carried out with the pump disconnected from any power sources. Do not operate the pump until it has reached a temperature that is not dangerous for the operator.



HAZARD

If pump maintenance has been performed in a manner inconsistent with instructions, with non-original spare parts or otherwise so as to impair its integrity or modify its characteristics, D.V.P. Vacuum Technology s.p.a. will be released from any liability relating to the safety of persons and malfunction of the pump.

6.2 MAINTENANCE TABLE

The following table shows all required periodic operations to maintain pump efficiency.

OPERATION TYPE	FREQUENCY	OPERATOR QUALIFICATION
Check the oil level and pump noise	24 h	
Change oil	500 h	
Check and clean gas ballast	1000 h	
Clean motor fan guard and clean pump	1000 h	
Change vanes	10000 h	

Shorter maintenance intervals may be required according to operating conditions (high temperature of intake gases, intake gases containing condensable vapours, etc.).

6.2.1 CHECK OIL LEVEL

Check that oil level is at mid-range of the oil sight glass. If not, see instructions in the following paragraph.

Check oil conditions. When dark, cloudy or emulsified, oil has been contaminated by intake substances. If the condition does not change even after having carried out the decontamination procedure (see point 5.1.3 “Oil cleaning” in this manual), replace the oil following the instructions given in point 6.2.2 “Change oil” in this manual.

Check that no odd noises are caused during the normal functioning of the pump; otherwise find and eliminate the cause. For any questions please contact D.V.P. Vacuum Technology s.p.a. customer service.

6.2.2 CHANGE OIL**HAZARD**

Before carrying out the operations listed below, isolate the pump from the operating system by means of an isolation valve (required in 4.8 "System User" of this manual) and from the power supply, then clean the surrounding area from the possible presence of a potentially explosive atmosphere (ATEX) due to the opening of the oil filler cap.

Change oil as follows:

- let the pump run with closed suction intake for about 10 minutes first so oil will become thinner;
- stop the pump and disconnect it from the mains;
- undo the oil filler plug;
- get a container large enough to hold all oil (see 3.3 "Dimensions and characteristics" of this manual) and open the oil drain plug;
- drain out all oil;
- close drain plug and fill in fresh oil through the filler plug up to mid-range on the oil sight glass;
- close the oil filler plug;
- Remove all oil spills from the pump and/or floor;
- connect to mains again and verify correct rotation direction of the pump (see 4.9.2 "Wiring" of this manual);
- let the pump run with closed intake for a few minutes and then, if necessary, top up oil if necessary.

**HAZARD**

Wear appropriate personal protection equipment to perform said operations.

**HAZARD**

Comply with local regulations regarding the collection and disposal of used or polluted oil.

6.2.3 CHECK AND CLEAN GAS BALLAST**HAZARD**

Before carrying out the operations listed below, isolate the pump from the operating system by means of an isolation valve (required in 4.8 "System User" of this manual) and from the power supply, then clean the surrounding area from the possible presence of a potentially explosive atmosphere (ATEX) due to the opening of the ballast.

Fully unscrew gas ballast and clean it thoroughly with compressed air. Change gasket if damaged.

6.2.4 CLEAN MOTOR FAN GUARD AND CLEAN THE PUMP**HAZARD**

The cleaning of the fan motor and pump protection devices is needed to remove dust deposits that might otherwise clog or cover rapidly the cooling surfaces, thus causing the deterioration of the safety level of the pump

This can be done using compressed air and a dry cloth.
Do not use fluids or substances other than those indicated.

**HAZARD**

Wear appropriate personal protection equipment to perform said operations.

6.2.5 CHANGE VANES**HAZARD**

Before carrying out the operations listed below, isolate the pump from the operating system by means of an isolation valve (required in 4.8 "System User" of this manual) and from the power supply, then clean the surrounding area from the possible presence of a potentially explosive atmosphere (ATEX) in the pump itself.

**HAZARD**

During the replacement operation of the palette, check for the presence of traces of rust on metal parts that could be due to aluminium thermal reactions.

The instructions for replacing vanes are available upon request.

6.3 SPARE PARTS

Use **Original Spare Parts** to replace pump parts.

When purchasing spare parts, always quote the serial number and model of the pump (these can be found on the identification plate) as well as the spare part purchase number.

DESCRIPTION	DC.16DEX
Kit minor	K9602028
Kit major	K9602028/1
Olio 1 dm ³	8833100 (SW100)
Olio 5 dm ³	8833500 (SW100)
Gas ballast gasket	1001018

D.V.P. Vacuum Technology s.p.a. disclaims all responsibility for any deterioration of pump performance or for damages caused due to use of non-original spare parts.



HAZARD

The use of non-original spare parts can degrade the level of protection of the pump and render the ATEX certification null and void.

7 HOW TO RETURN THE PUMP

The product may only be returned after prior agreement with the supplier, who will provide the authorisation number that must accompany the material delivered and should be duly complete in its entirety.

8 DISMANTLING

**HAZARD**

Before carrying out the disposal operations of the pump it is necessary to clear out any potentially explosive atmospheres (ATEX) contained within it.

Demolition of the pump must be performed by authorised technicians.

Metal parts can be disposed of as scrap metal.

All materials deriving from demolition must be disposed of according to regulations in the country where the pump will be demolished.

**HAZARD**

Disposal operations involve risks of cutting, shavings protection, entanglement, contact with moving parts and contact with chemicals. Operators should use the appropriate personal protective equipment.

9 TROUBLESHOOTING

DAMAGE	CAUSE	REMEDY
(A) The pump does not run	No voltage	Provide power supply
	Thermal switch has tripped	Identify reason and activate switch
	Room temperature is too low	Restore room temperature to allowed range
	Intake of not allowed substances	Contact Service Department
	Motor winding damaged	Contact Service Department
(B) The pump cannot reach stated final pressure (Abs.)	Low oil in tank	Top up oil
	Oil contaminated	Change oil
	Oil is not the suitable type	Change oil
	Wrong motor rotation	Check electrical wiring
	Gas ballast is open	Close gas ballast
	Discharge clogged	Check couplings at outlet
	Intake filter clogged (if present)	Clean the filter
(C) Pump is noisy	Motor coupling damaged (where present)	Contact Service Department
	Bearings damaged	Contact Service Department
	Vanes worn out	Contact Service Department
	Wrong motor rotation	Check electrical wiring
(D) Pump runs hot	Oil is not the suitable type	Change oil
	Oil contaminated	Change oil
	Poor room ventilation	Install an auxiliary ventilator
	Motor fan broken	Contact Service Department
	Motor fan guard clogged	Clean motor fan guard
	Wrong power supply to motor	Check power supply
	Discharge clogged	Check couplings at outlet
(E) High oil consumption	High working pressure (close to atmospheric pressure)	Check oil level frequently
	Pump runs hot	See point "D"
(F) Pump does not maintain vacuum after power-off	Check valve/system damage	Contact Service Department
(G) Pump leaks oil	Tank screws or plugs loosened	Tighten screws or plugs
	Tank gaskets damaged	Contact Service Department
	Oil sight glass not tightened	Tighten the oil sight glass

GENERAL CONDITIONS OF SALE

D.V.P. Vacuum Technology s.p.a. supplies products exclusively for professional clientele, hence, excluding consumers.

PRODUCT WARRANTY TERMS AND CONDITIONS

D.V.P. Vacuum Technology s.p.a. guarantees that the product is free from material or manufacturing defects for a period of 24 months of normal use from the shipping date. This period is of 6 months of normal use for products subject to repair not under warranty.

Normal use means an operating cycle of 8 hours per day for a maximum of 5000 operating hours in the 24 months covered by the warranty.

Warranty means the free replacement or repair at its own assistance network of any components of the product that are found to be faulty from the start due to manufacturing defects.

In the event of repair, D.V.P. Vacuum Technology s.p.a. guarantees, exclusively to its own customer, the identical spare parts for 24 months from the shipping date; once this period has passed, the pieces may no longer be available on the market, therefore the repairs, even under warranty, may require the payment of a difference between the product purchased and that installed during the repair. This price will be indicated to the customer before the repair is carried out, for acknowledgement and acceptance.

D.V.P. Vacuum Technology s.p.a. will do everything reasonable within its power to respect the assistance times and *standard* response (20 working days), which may vary according to the distance and accessibility of the place where the product is located and the availability of the components.

D.V.P. Vacuum Technology s.p.a. will not be held responsible for any direct or indirect losses caused by its failure to respect the assistance times and will not have any responsibility or contractual or civil obligation for product faults or for failure to repair the faults in a reasonable period of time.

In the event of irreparable faults, the product will be replaced. The replacement will cause the original warranty to be extended to the new product, until its expiry date.

The warranty does not cover any parts that appear to be faulty due to negligence and/or carelessness during use (failure to observe the equipment operating instructions, lack of maintenance), incorrect installation and/or maintenance, maintenance carried out by unauthorized staff, damage due to transport, or circumstances which, in any case, cannot be attributed to manufacturing faults on the equipment.

The warranty also excludes all components of the product that have been modified or repaired without prior written authorisation from D.V.P. Vacuum Technology s.p.a.

The warranty also excludes any faults deriving from improper use, normal wear, galvanic and electrostatic currents, chemical corrosion, tampering, replacement or elimination of the registration plate.

The warranty does not cover, in any case, faults generated by external causes, such as accidents and fortuitous events.

D.V.P. Vacuum Technology s.p.a. declines all responsibility to anyone for any damage and, consequence, of any kind and/or reason, that may derive from the use of the product, as well as for any faults that it may present.

By way of non-limiting example, it declines all responsibility:

- for any damage that could, directly or indirectly, be caused to people, objects and animals, due to failure to observe all the instructions indicated in the relevant use and maintenance manual, especially the indications on the installation, use and maintenance of the equipment;
- for any damage and/or loss caused by faults of deficiencies of products repaired by D.V.P. Vacuum Technology s.p.a.;
- for any indirect or consequential damage such as, by way of non-limiting example, loss of business, profits, salaries, payments etc.;
- losses that could have been avoided by the customer by following the advice and instructions from D.V.P. Vacuum Technology s.p.a..

In any case, the customer waives the right to claim any right and/or demand as well as raising any objection or promoting any action, inherent to the use of the product.

The warranty is not extended to consumable parts, or faults deriving from: filtering cartridges, blades, membranes or sealing rings, as well as third party products that are part of the final product.

The transport, removal and subsequent re-installation costs of the repaired or replaced product are, however, to be entirely borne by the customer.

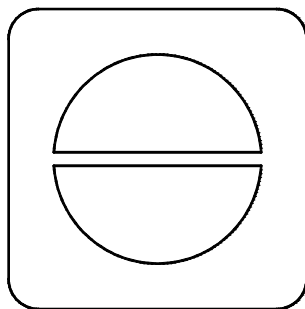

D.V.P. Vacuum Technology s.p.a.
Via Rubizzano, 627
40018 San Pietro in Casale (BO) – Italy
Ph +3905118897101
Fx +3905118897170
www.dvp.it

Cod. 8702042 – 12/04/2016 – R.5 – (EN)